

INDUSTRIAL PRODUCT DATASHEET

# Hightorque HTDW-6056-36-NE-JC 1:36 Gear Motor CAN

Highly-integrated gear motor with daisy-chain capability for robot arm and biped humanoid applications.

SKU

100036262

UPDATED

2026-06-10 12:11:10

PRICE

\$229.00(Excl. VAT)

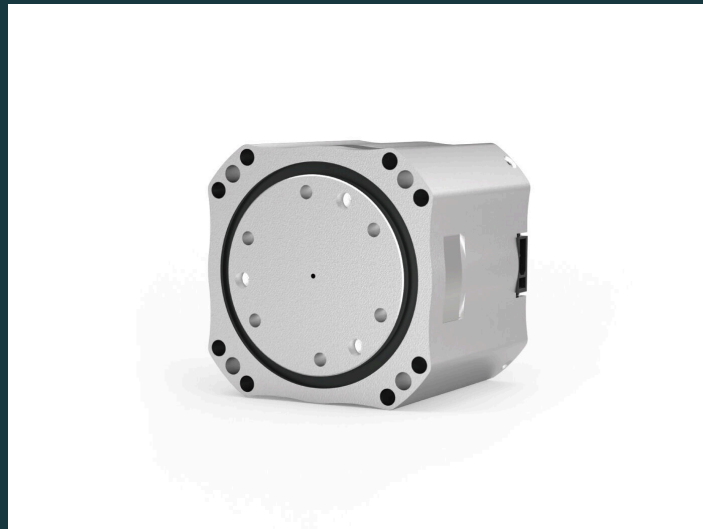

# Overview

---

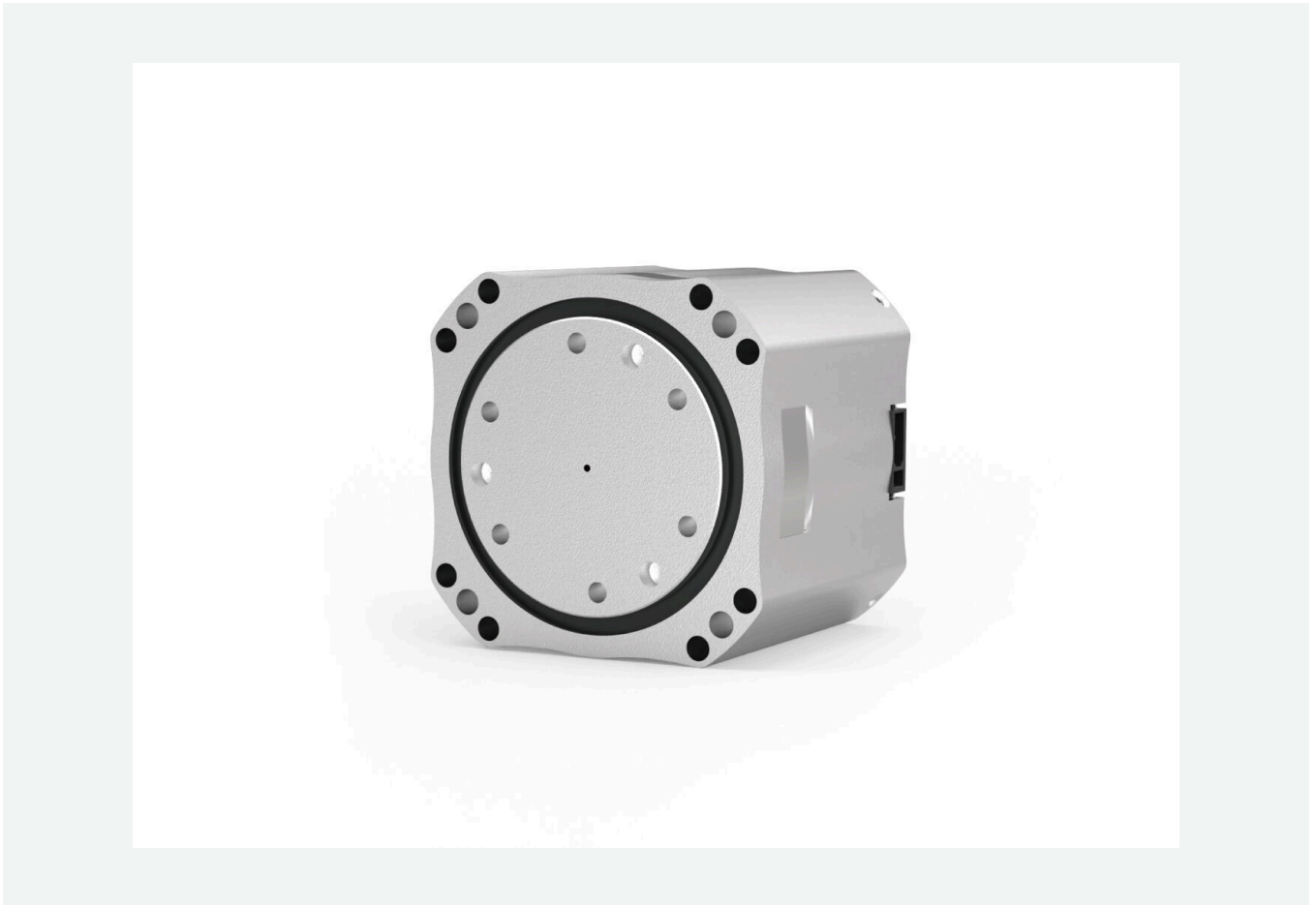

The Hightorque HTDW-6056-36-NE-JC 1:36 Gear Motor CAN is a highly-integrated motor combining a frameless torque motor, absolute encoder, driver circuitry, and planetary reducer. It features daisy-chain capable XT30 connectors, dual encoder multi-turn absolute positioning, and 24V battery compatibility for robot arm and biped humanoid applications.

## Key Features

---

- **Highly-integrated** Includes frameless torque motor, absolute encoder, driver circuitry and planetary reducer
- **Simple connection** Has two XT30(2+2) connectors suitable for daisy-chain connection without special cable modifications
- **Dual Encoder** Enables multi-turn absolute position recognition
- **Battery power compatible** Could be used in 24V battery-powered system
- **Daisy-chain capable** Can connect multiple Hightorque motors in series using XT30 cables for robotics applications

## Specification

---

Product	Hightorque HTDW-6056-36-NE-JC Motor
Voltage Range	12-48V
Operating Temperature	-20°C~40°C
Mechanical Dimension	60mm x 60mm x 56mm
Communication Interface	CAN-FD & CAN
Gear Ratio	1:36
Rated Output Power	52 W
Rated Torque	10 Nm
Peak Torque	36 Nm
Pole pair	14

# Hardware Overview

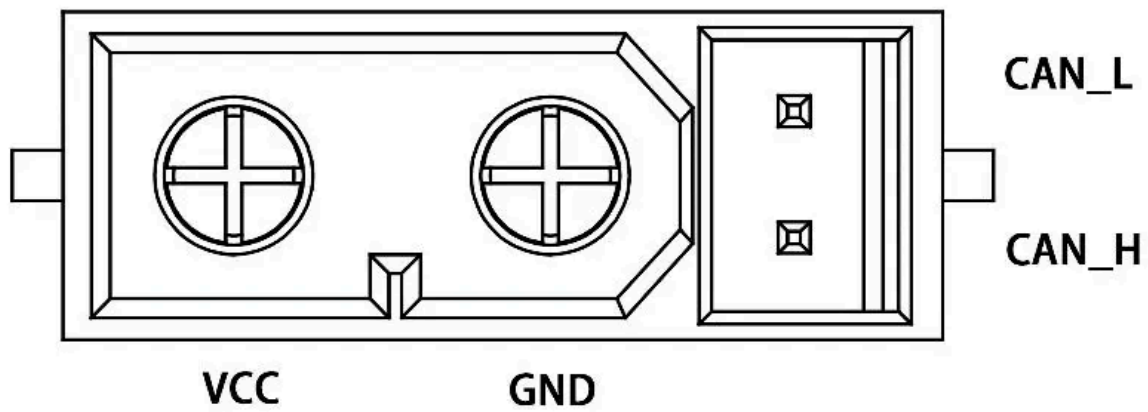
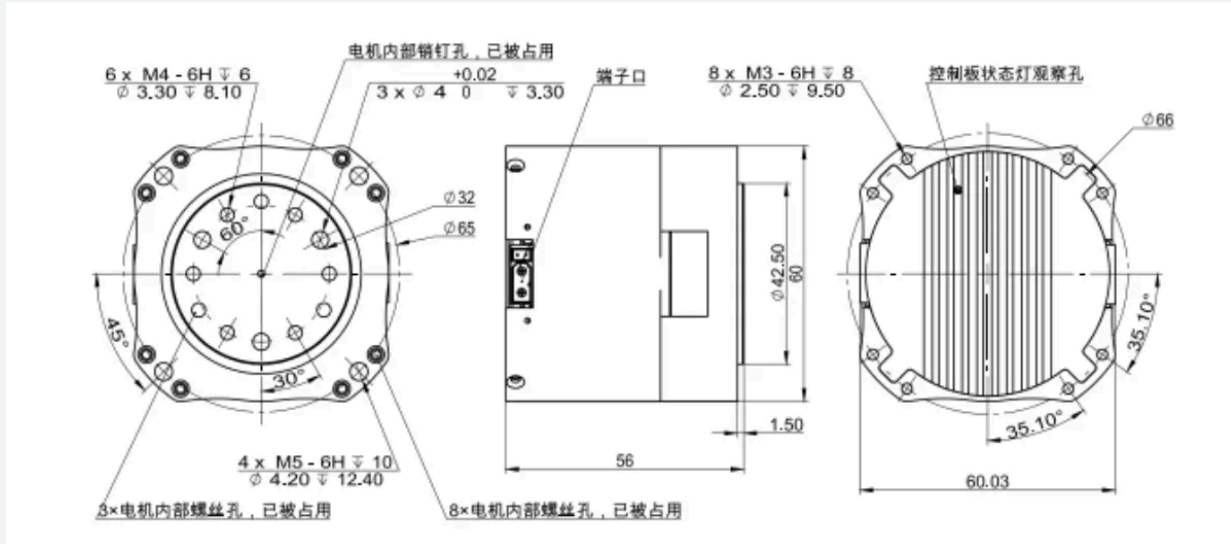

# Applications

- Robot Arm
- Biped Humanoid

## Part List

Hightorque HTDW-6056-36-NE-JC Motor	x1
XT30(2+2) Cable	x1

## Compliance & Logistics

HSCODE	8501310000
USHSCODE	8501316000
UPC	
EUHSCODE	8501109390
COO	CHINA

## Resource Links

- <https://www.seeedstudio.com/Hightorque-HDTW-6056-36-NE-JC-Actuator-p-6673.html>
- [Datasheet](#)
- [User Manual](#)
- [SDK\(CAN\)](#)
- [CANProtocol](#)
- [wiki](#)

**Seeed Technology Co.,Ltd.**  
9F, Building G3, International E City,  
Zhongshanyuan Road, Nanshan, Shenzhen, China

**Tel:** +86 0755-80695676  
**Web:** [www.seeed.cc](http://www.seeed.cc)  
**Shop:** [www.seeedstudio.com](http://www.seeedstudio.com)