

INDUSTRIAL PRODUCT DATASHEET

# Hightorque HTDW-5047-36 1:36 Gear Motor CAN

Highly-integrated planetary gear motor with daisy-chain capability, dual encoder, and 24V battery compatibility for advanced robotics.

SKU

114090072

UPDATED

2026-06-10 12:06:17

PRICE

\$189.00(Excl. VAT)



# Overview

---



The Hightorque HTDW-5047-36 1:36 Gear Motor CAN is a highly-integrated solution combining a frameless torque motor, absolute encoder, driver circuitry, and planetary reducer. Its daisy-chain capability via dual XT30(2+2) connectors and multi-turn absolute position recognition make it ideal for battery-powered robot arms and biped humanoids.

## Key Features

---

- **Highly-integrated** Includes frameless torque motor, absolute encoder, driver circuitry and planetary reducer
- **Simple connection** Has two XT30(2+2) connectors suitable for daisy-chain connection without special cable modifications
- **Dual Encoder** Enables multi-turn absolute position recognition
- **Battery power compatible** Could be used in 24V battery-powered system
- **Daisy-chain capable** Can connect multiple Hightorque motors in series using XT30 cables for robotics applications

# Product Gallery

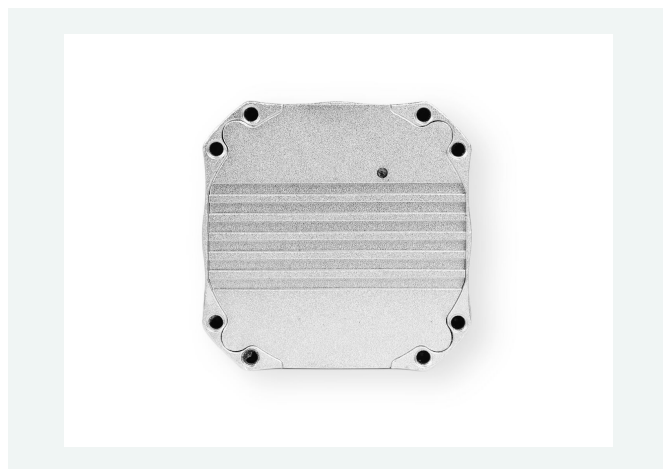
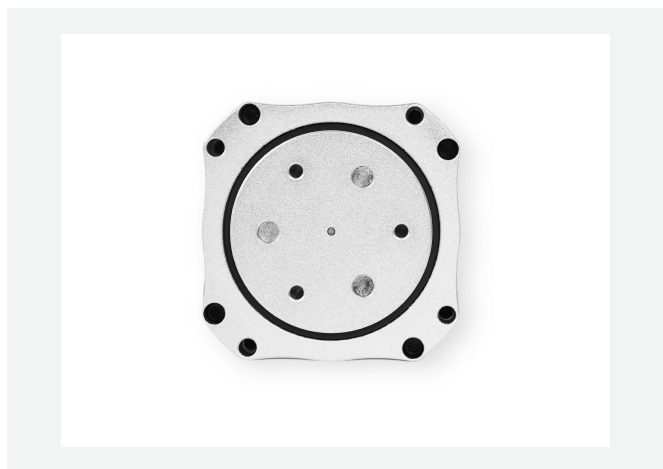

## Specification

|                       |                               |
|-----------------------|-------------------------------|
| Product               | Hightorque HTDW-5047-36 Motor |
| Rated Voltage         | 24V                           |
| Operating Temperature | -20°C~40°C                    |

|                         |                    |
|-------------------------|--------------------|
| Mechanical Dimension    | 50mm x 50mm x 47mm |
| Communication Interface | CAN-FD             |
| Gear Ratio              | 1:36               |
| Rated Output Power      | 17 W               |
| Rated Torque            | 4 Nm               |
| Peak Torque             | 16 Nm              |
| Pole pair               | 14                 |

# Hardware Overview

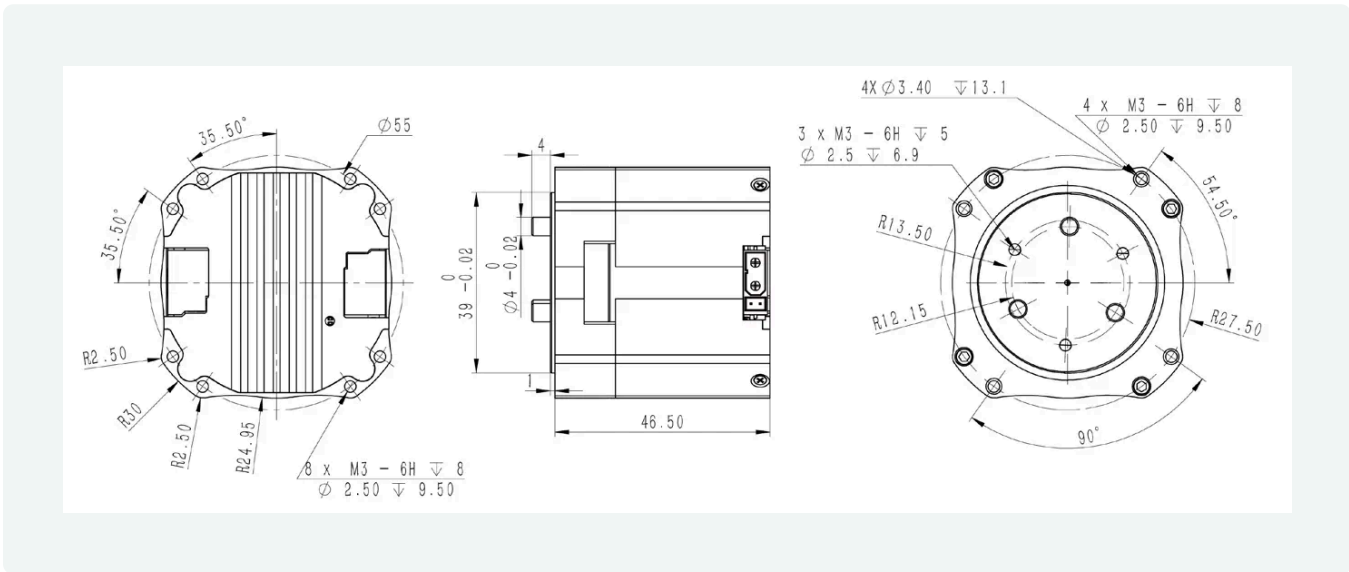

# Applications

- Robot Arm
- Biped Humanoid

## Part List

|                               |    |
|-------------------------------|----|
| Hightorque HTDW-5047-36 Motor | x1 |
| XT30(2+2) Cable               | x1 |

## Compliance & Logistics

---

|          |            |
|----------|------------|
| HSCODE   | 8501109990 |
| USHSCODE | 8501106080 |
| UPC      |            |
| EUHSCODE | 8501109390 |
| COO      | CHINA      |

## Resource Links

---

- <https://www.seeedstudio.com/Hightorque-HTDW-5047-36-NE-Gear-Motor-p-6483.html>
- [Datasheet](#)
- [User Manual](#)
- [SDK\(CAN\)](#)
- [CANProtocol](#)

**Seeed Technology Co.,Ltd.**

9F, Building G3, International E City,  
Zhongshanyuan Road, Nanshan, Shenzhen, China

**Tel:** +86 0755-80695676

**Web:** [www.seeed.cc](http://www.seeed.cc)

**Shop:** [www.seeedstudio.com](http://www.seeedstudio.com)