

HSZ	深圳市宏盛泽能源科技有限公司 <b>Shenzhen HSZ EnergyTechnology Co.,Ltd</b>	文件编号:
	IFR18650-2000mAh-2S1P规格承认书	HSZ-SPE-RD-2380C

Ver: A1

Date: 2025.10.31

## Specification Approval Sheet

### 磷酸铁锂电池规格承认书

此规格书为标准版，具体以双方签字为准。

型 号: IFR18650-2S1P-2000mAh

Model: IFR18650-2S1P-2000mAh

类 型: 磷酸铁锂电池

Type: LiFePO4 battery

制定人 Prepared by	审核人 Checked by	批准人 Approved by
胡立秋	丁新建	张伟
业务签名		
客户承认 Customer Approval	客户编号: Customers No.:	
	客户签名: Customers Signature:	

规格书修订记录

HSZ	深圳市宏盛泽能源科技有限公司 <b>Shenzhen HSZ EnergyTechnology Co.,Ltd</b>	文件编号： HSZ-SPE-RD-2380C
	IFR18650-2000mAh-2S1P规格承认书	

History of specification

日期 Date	内容 Contents	备注 RemarkSs
2025.10.11	First issue 新发行	A0 版
2025.10.31	Line length update 线长更新	A1 版
2025.10.31	Thickness update 厚度更新	A1 版

地址 1: 深圳市龙岗区坪地街道同富路富地岗第二工业区顺富科技园 5 栋

Add1: Shun Fu science and Technology Park 5 TongfuRoad NO.2 Industrial Zone Pingdi street Longgang District Shenzhen

地址 2:广东省东莞市桥头镇力嘉工业园 4 栋 5-6 楼

ADD2: Floor 5--6,buuilding 4,lijia packaging industrial park,qiaotou town,Dngguan city.

邮编: 518000 P.C.: 518000

电话@传真: 0755-89260083

Tel.@ Fax: 0769-81029525

HSZ	深圳市宏盛泽能源科技有限公司 <b>Shenzhen HSZ EnergyTechnology Co.,Ltd</b>	文件编号:
	IFR18650-2000mAh-2S1P规格承认书	HSZ-SPE-RD-2380C

## Contents

1	Scope fan 范围 .....	4
2	Product and Model Name 产品种类及型号 .....	4
2.1	Product 产品种类 .....	4
2.2	Model Name 产品型号 .....	4
3	Ratings 主要技术参数 .....	4
4	Dimensions and Appearance 外形尺寸及外观 .....	5
4.1	Dimensions 外形尺寸 .....	5
4.2	Appearance 外观 .....	5
5	Performance 性能 .....	5
5.1	Standard Test Conditions 标准测试条件 .....	5
5.2	Measuring Instrument or Apparatus 测试设备 .....	5
5.3	Standard Charge 标准充电 .....	6
5.4	Rest Period 搁置时间 .....	6
5.5	Initial Performance Test 初始性能测试 .....	6
5.6	Electrical Performance 电性能 .....	7.8
5.7	Mechanical Performance 机械性能 .....	9
5.8	Safety Performance 安全性能 .....	10
6	Electrical Characteristic 电气特性 .....	11
7	Application Circuit 线路板原理图 .....	11
8	PCM BOM LIST 保护板元件清单 .....	12
9	Handling Instructions 电池使用指南 .....	12、13
10	Period of Warranty 保质期 .....	14
11	Delivery Condition 运输条件 .....	14
12	Note 备注 .....	14
Fig.1	Dimensional Drawing of 外形尺寸图 .....	15

HSZ	深圳市宏盛泽能源科技有限公司 <b>Shenzhen HSZ Energy Technology Co., Ltd</b>	文件编号:
	IFR18650-2000mAh-2S1P规格承认书	HSZ-SPE-RD-2380C

### 1 Scope 适用范围

This specification is applied to Lithium Iron Phosphate battery manufactured by HSZ Energy Technology Co.,LTD

本产品规格书适用于宏盛泽能源科技有限公司生产的磷酸铁锂电池。

The product is ROHS compliant

本产品符合 ROHS 标准。

### 2 Product and Model Name 产品种类及型号

2.1 Product 产品种类: 18650Lithium Iron Phosphate battery IFR18650 磷酸铁锂电池

2.2 Model Name 产品型号: IFR18650-2S1P-2000mAh

### 3 Ratings 主要技术参数

Item 项目		Rating 内容	Note 备注
3.1 Capacity 容量	Typical 典型	2000mAh	Discharge:0.2CmA , 0.2C 放电
	Minimum 最小	1950mAh	
	Energy 能量	12.8Wh	
3.2 Nominal Voltage 额定电压		6.4V	
3.2 AC Impedance Resistance 内阻		≤220mΩ	(含 PCB)
3.4 Discharge Cut-off Voltage 放电截至电压		4.0V	
3.5 Charge Voltage 充电电压		7.3V	
3.6 Max. Charge Voltage 最大充电电压		7.3V	
3.7 Standard charge current 标准充电电流		400mA	0~5℃ 0.2CmA
		600mA	5~15℃ 0.3mA
3.8 Max. Charge Current 最大充电电流		1000mA	15~45℃ 1.0CmA
3.9 Max. discharge current 最大放电电流		6000mA	3CmA
3.10 Weight 重量		Approx : g	
3.12 Operating Temperature 工作温度	Charge 充电	0~+45℃	
	Discharge 放电	-20~+60℃	
3.13 Storage Temperature 存储温度	less than 1 month 小于 1 个月	-10~+45℃	Recommended storage temperature: 20-25℃, at the transportation 运输时存储温度 20-25℃。
	less than 6 months 小于 6 个月	-10~+35℃	
3.14 Shipment voltage 出货电压		6.0-6.8V	

HSZ	深圳市宏盛泽能源科技有限公司 <b>Shenzhen HSZ Energy Technology Co., Ltd</b>	文件编号:
	IFR18650-2000mAh-2S1P规格承认书	HSZ-SPE-RD-2380C

#### 4 Outline Dimensions and Appearance 电池外形尺寸及外观

##### 4.1 Outline Dimensions 外形尺寸

See attached drawing for 电池外形尺寸参见“IFR18650-2S1P(Fig.1).外形尺寸图”。

This thickness will be swelling when high temperature storage or operation in high temperature.

备注：电池在高温下贮存或使用时厚度会发生膨胀。

##### 4.2 Appearance 外观

There shall be no such defect as scratch, flaw, crack, rust, leakage, which may adversely affect Commercial value of battery.

电池外表面清洁，无电解液泄漏，无明显的划痕及机械损伤，无变形，无影响电池价值的其它外观缺陷。

#### 5 Performance 性能

##### 5.1 Standard Test Conditions 标准测试条件

Test should be conducted with new batteries within one month after shipment from our factory and the cells shall not be cycled more than five times before the test. Unless otherwise defined, test and measurement shall be done under temperature of  $25\pm 2^{\circ}\text{C}$  and relative humidity of 45~85%. The test results are not affected evidently by such conditions of temperature 15~30°C or humidity 25~85%RH.

测试电池必须是本公司出厂时间不超过一个月的新电池，且电池未进行过五次以上充放电循环。除非其它特殊要求，本产品规格书规定的测试条件为：温度  $25\pm 2^{\circ}\text{C}$ ，相对湿度 45%~75%。如果已经证明测试结果不受这些测试条件影响，实验也可以在温度 15~30°C，相对湿度 25%~85%的条件下进行。

##### 5.2 Measuring Instrument or Apparatus 测试设备

###### 5.2.1 Dimension Measuring Instrument 尺寸测量工具

The dimension measurement shall be implemented by instruments with equal or more Precision scale of 0.01mm.

测量尺寸的仪器精度应大于等于 0.01mm

###### 5.2.2 Voltmeter 万用表

Standard class specified in the national standard or more sensitive class having inner impedance more than 10 MΩ

万用表测量电压及电流的准确度应不低于 0.5 级，测量电压时内阻不应小于 10 MΩ。

###### 5.2.3 Impedance Meter 阻抗法

Impedance shall be measured by a sinusoidal alternating current method (1kHz LCR meter).

内阻测试仪测量原理应为交流阻抗法（1kHz LCR）。

HSZ	深圳市宏盛泽能源科技有限公司 <b>Shenzhen HSZ Energy Technology Co., Ltd</b>	文件编号:
	IFR18650-2000mAh-2S1P规格承认书	HSZ-SPE-RD-2380C

### 5.3.1 Standard charge current 标准充电电流

0.2CmA=400mA

### 5.3.2 Max. Charge Current 最大充电电流

1.0CmA=2000mA

Full charge condition: Constant current 1.0CmA to 7.3V, Constant voltage 7.3V to 0.02C in all at 25±2°C.

满充条件: 0.2C 恒流充至 7.3V, 然后 7.3V 恒压充电至截止电流为 0.01C, 在 25±2°C 环境下充电;

### 5.4 Rest Period 搁置时间

Unless otherwise defined, 10min, rest period after charge, 10min, rest period after discharge.

如无特殊要求, 电池充满电搁置 10min, 电池放完电了搁置 10min.

### 5.5 Initial Performance Test 初始性能测试

Item 项目	Measuring Procedure 测试方法	Requirements 要求
(1) Open-Circuit Voltage 开路电压	The open-circuit voltage shall be measured within 24 hours after standard charge. 标准充电后, 24 小时内测量开路电压	≥6.4V
(2) AC Impedance Resistance 内阻	The Impedance shall be measured in an alternating current method (1kHz LCR meter) after standard charge at 25±2°C. 标准充电后, 在 25±2°C 采用交流法测量内阻	≤220mΩ
(3) Minimum Capacity 最小容量	The capacity on 0.2CmA discharge shall be measured after standard charge at 25±2°C (specified C5). 标准充电后, 搁置 30min, 0.2CmA 放电至 6v, 测试池容量该容量定义为 C5)	C5≥1950mAh
(4) 0.5CmA Discharge Capacity 0.5CmA 放电容量	The capacity on 0.5CmA discharge shall be measured after standard charge 标准充电后, 测试 0.5C 放电容量	Discharge Capacity 放电容量≥95%C5

HSZ	深圳市宏盛泽能源科技有限公司 <b>Shenzhen HSZ Energy Technology Co., Ltd</b>	文件编号:
	IFR18650-2000mAh-2S1P规格承认书	HSZ-SPE-RD-2380C

## 5.6 Electrical Performance 电性能测试

### 5.6.1 Cycle Life 循环性能

Item 项目	Measuring Procedure 内容	Requirements 备注
循环寿命 (25°C) Cycle Life @25°C	先用 0.5C 恒流充电至 7.3V 恒压 7.3V 直至充电电流 $\leq 0.01C$ , 搁置 10 分钟, 再用 0.5C 电流放电至 4.0V; 又搁置 10 分钟, 重复以上步骤, 直到放电容量是初始容量的 80% 结束。Constant current 0.5C charge to 7.3V, then constant voltage charge to current declines to 0.01C, rest 10min, constant current 0.5C discharge to 4.0V, rest 10min. Repeat above steps till continuously discharging capacity Higher than 80% of the Initial Capacities of the Cells.	循环次数 $\geq 300$ 次  Cycle life $\geq 300$

### 5.6.2 Shelf Life 荷电保持能力

Item 项目	Measuring Procedure 内容	Requirements 备注
Storage Characteristics 1 贮存特性 1	1 The capacity on 0.5CmA discharge shall be measured after standard charge and then storage at $25\pm 2^\circ\text{C}$ for 30 days. 标准充电后电池在 $25\pm 2^\circ\text{C}$ 的环境中贮存 30 天, 测试 0.5CmA 放电容量 (保持容量)	Remaining Capacity $\geq 85\% C5$ 容量保持 $\geq 85\% C5$
	2 After above measured Remaining capacity, the capacity on standard discharge shall be measured after standard charge. 经过以上剩余容量测试后, 测试标准充电后的放电容量 (3 周循环的最大放电容量)	Recovery capacity $\geq 90\% C5$ 容量恢复 $\geq 90\% C5$
Storage Characteristics 2 贮存特性 2	1 The capacity on 0.5CmA discharge shall be measured after standard charge and then storage at $60\pm 2^\circ\text{C}$ for 7 days. 标准充电后电池在 $60\pm 2^\circ\text{C}$ 的环境中贮存 7 天, 测试 0.5CmA 放电容量 (保持容量)	Remaining Capacity $\geq 60\% C5$ 容量保持 $\geq 60\% C5$
	2 After above measured Remaining capacity, the capacity on standard discharge shall be measured after standard charge. 经过以上剩余容量测试后, 测试标准充电后的放电容量 (3 周循环的最大放电容量)	Recovery capacity $\geq 80\% C5$ 容量恢复 $\geq 80\% C5$

### 5.6.3 Long Time Storage Characteristics 长期贮存性能

HSZ	深圳市宏盛泽能源科技有限公司 <b>Shenzhen HSZ EnergyTechnology Co.,Ltd</b>	文件编号:
	IFR18650-2000mAh-2S1P规格承认书	HSZ-SPE-RD-2380C

After about half charge after a period of storage at  $25 \pm 2^{\circ}\text{C}$  for one year (365 days). The recovery available capacity is  $\geq 85\%$  C5. The capacity is determined with the capacity of the by the most of preceding three cycles.

进行该项实验的电池应选生产日期到实验日期不足 3 个月的电池，贮存前给电池充入 50% 的容量，然后开路搁置 365 天，在  $25 \pm 2^{\circ}\text{C}$  的环境条件下 0.2CmA 循环 3 次，测试恢复容量（3 周循环的最大放电容量），要求如下：容量恢复  $\geq 85\%$  C5。

#### 5.6.4 Plants. the self-discharge 常温自放电

The battery charging cross-flow 360min, voltage to 7.2 V, then will the battery in normal temperature environment, open 24h, battery off pressure aside for 10 millivolts

将电池恒流恒压 0.2C 充电 360min, 截止电压 7.2V, 然后将电池放在常温环境下, 开路搁置 24h, 电池掉压为 10 毫伏。

HSZ	<b>深圳市宏盛泽能源科技有限公司</b> <b>Shenzhen HSZ Energy Technology Co., Ltd</b>	文件编号:
	<b>IFR18650-2000mAh-2S1P规格承认书</b>	HSZ-SPE-RD-2380C

### 5.7 Mechanical Performance 机械特性

Item 项目	Measuring Procedure 测试方法	Requirements 要求
Vibration test 振动	After standard charge, the battery is to be tested as following conditions: Amplitude:0.19mm Frequency:10~55Hz(sweep:1Hz/min) Direction: X/Y/Z axis for 30min. The battery is to be tested in three mutually perpendicular to each axis. 标准充电后, 将电池安装在振动台上, 在 X、Y、Z 三个垂直方向进行实验, 振动频率在 10~55Hz 间以 1Hz/min 的速度变化, 位移振幅: 0.19mm, 往复振动 30min。	Battery no electrolyte leakage, smoke or explosion battery voltage $\geq 4.0\text{ V}$ .  电池无漏液、冒烟或爆炸 电池电压 $\geq 4.0\text{V}$ 。
Drop Test 自由跌落	Drop the battery in the shipment condition(full-charge)from 1m height onto 18~20 mm or thicker concrete with p-tile on it 1 times each of obverse and inverse directions at $25\pm 2^{\circ}\text{C}$ 电池振动试验结束后按下列条件进行自由跌落试验: 跌落高度: 1.0m; 承接物: 18~20mm 厚硬木板; 跌落方向: 沿水平方向正反面各跌落一次。	No fire, no explosion, no smoking is obtained. 电池无漏液、冒烟或爆炸
Constant Humidity and Temperature Characteristics 恒定湿热	Under the temperature of $20\pm 5^{\circ}\text{C}$ , after charging the battery with 0.2C, then put the battery into the constant temperature and humidity oven with $55\pm 2^{\circ}\text{C}$ and 90~95% for 48h, the battery should be no obvious deformation, leakage, rust, smoking and explosion. After testing take out the battery then rest for 2h under the temperature of $20\pm 5^{\circ}\text{C}$ , discharge with 1C to 4.0V. 在 $20\pm 5^{\circ}\text{C}$ 条件下, 电池按 0.2C 充电结束后, 放入 $40\pm 2^{\circ}\text{C}$ , 湿度 90~95% 的恒温恒湿箱内 48h, 电池应无明显变形、漏液、生锈、冒烟或爆炸, 试验结束后将电池取出搁置 2h, 在 $20\pm 5^{\circ}\text{C}$ 条件下, 以 1C 放电至 4.0V。	discharge capacity $\geq 60\%$ C5 放电容量 $\geq 60\%$ C5

HSZ	深圳市宏盛泽能源科技有限公司 Shenzhen HSZ Energy Technology Co., Ltd	文件编号:
	IFR18650-2000mAh-2S1P规格承认书	HSZ-SPE-RD-2380C

### 5.8 Safety Performance 安全性能

Item 项目	Measuring Procedure 内容	Requirements 备注
Short-Circuit Test 短路测试	After standard charge, the battery is to be short-circuited by connecting the positive and negative terminals of the battery with copper wire having a maximum resistance load of 0.1Ω. 标准充电后, 用 0.1Ω的铜线短路电池的正负极。	No explosion, no fire. The temperature of the exterior cell casing shall not exceed 160°C. 不爆炸, 不起火, 电池外部温度不超过 160°C.
Heating Test 热冲击测试	A battery is to be heated in a gravity convection or circulating air oven. The temperature of the oven is to be raised at a rate of 5±2°C/min to a temperature of 130±2°C at which temperature the oven is to remain for 30 minutes before the test is discontinued. 电池放于热箱中, 温度以 (5±2°C) /min 的速率升至 130±2°C 并保温 30min。	No explosion, no fire. 不爆炸, 不起火
Abnormal Charging Test 过充电测试	After standard charge, the battery is subjected to a charging current by connecting it to a dc-power supply. The beginning current is 3.0C, which is to be obtained by connecting a resistor of specified size and rating in series with the battery; the voltage of the dc-power supply is 8V. The test time is 2.5 hours. 标准充电后, 电池及滑动变阻器串联于一恒流恒压源, 电压调节为 8V, 通过滑动变阻器调节电流至 3.0CmA, 然后对电池以 3.0CmA 充电。测试时间为 2.5H。	No explosion, no fire. 不爆炸, 不起火
Overdischarge Test 过放电测试	The fully discharged cell is continually discharged for 24h with the (30×n) Ω load at 23±2°C. 电池在环境温度 23±2°C 的条件下, 以 0.2C <sub>5</sub> A 放电至终止电压后, 外接(30×n)Ω负载放电 24h。	No explosion, no fire. 电池不起火、不爆炸

HSZ	深圳市宏盛泽能源科技有限公司 <b>Shenzhen HSZ EnergyTechnology Co.,Ltd</b>	文件编号:
	IFR18650-2000mAh-2S1P规格承认书	HSZ-SPE-RD-2380C

6 电气特性 Electrical Characteristic			
Item 项目	Symbo 符号	Content 详细内容	Criterion 标准
Over charge Protection 过充保护	V <sub>DET1</sub>	Over charge detection voltage 过充电检测电压	3.65±0.025V
	tV <sub>DET1</sub>	Over charge detection delay time 过充电检测延迟时间	1000±300ms
	V <sub>REL1</sub>	Over charge release voltage 过充电解除电压	3.45±0.05V
Over discharge protection 过放保护	V <sub>DET2</sub>	Over discharge detection voltage 过放电检测电压	2.0±0.08V
	V <sub>DET2</sub>	Over discharge release voltage 过放电释放电压	2.5±0.1V
	tV <sub>DET2</sub>	Over discharge detection delay time 过放电检测延迟时间	110±40ms
Over current protection 过流保护	I <sub>DP</sub>	charging Overcurrent Protection Current 充电过流保护电流	-
	I <sub>DP</sub>	Discharge Overcurrent Protection Current 放电过流保护电流	9.5A±4A
	tV <sub>DET3</sub>	Over current Detection delay time 过电流检测延迟时间	10±4.0ms
		Release condition 保护解除条件	Cut load 断开负载
Short protection 短路保护		Detection condition 保护条件	Exterior short circuit 外部电路短路
	T <sub>SHORT</sub>	Detection delay time 检测延迟时间	300±200us
		Release condition 保护解除条件	Cut short circuit 断开短路电路
Interior resistance 内阻	R <sub>DS</sub>	Main loop electrify resistance 主回路通态内阻	R <sub>DS</sub> ≤50mΩ
Current consumption 消耗电流	I <sub>DD</sub>	Current consume in normal operation 工作时电路内部消耗	15.0 μA Max
Current consumption 消耗电流	I <sub>DD</sub>	Current consume in normal operation 休眠时电路内部消耗	3.0uA Max
建议工作电流		最大持续充/放电电流	-
建议工作温度		工作温度	-10℃~60℃
0V 充电		是否可以向 0V 电池充电功能	YES

HSZ	深圳市宏盛泽能源科技有限公司 <b>Shenzhen HSZ EnergyTechnology Co.,Ltd</b>	文件编号:
	IFR18650-2000mAh-2S1P规格承认书	HSZ-SPE-RD-2380C

短路恢复		是否有短路自动恢复功能	YES
休眠功能		是否有休眠功能(有休眠功能的解除条件为充电激活)	NO

### 7 线路板原理图 Application Circuit

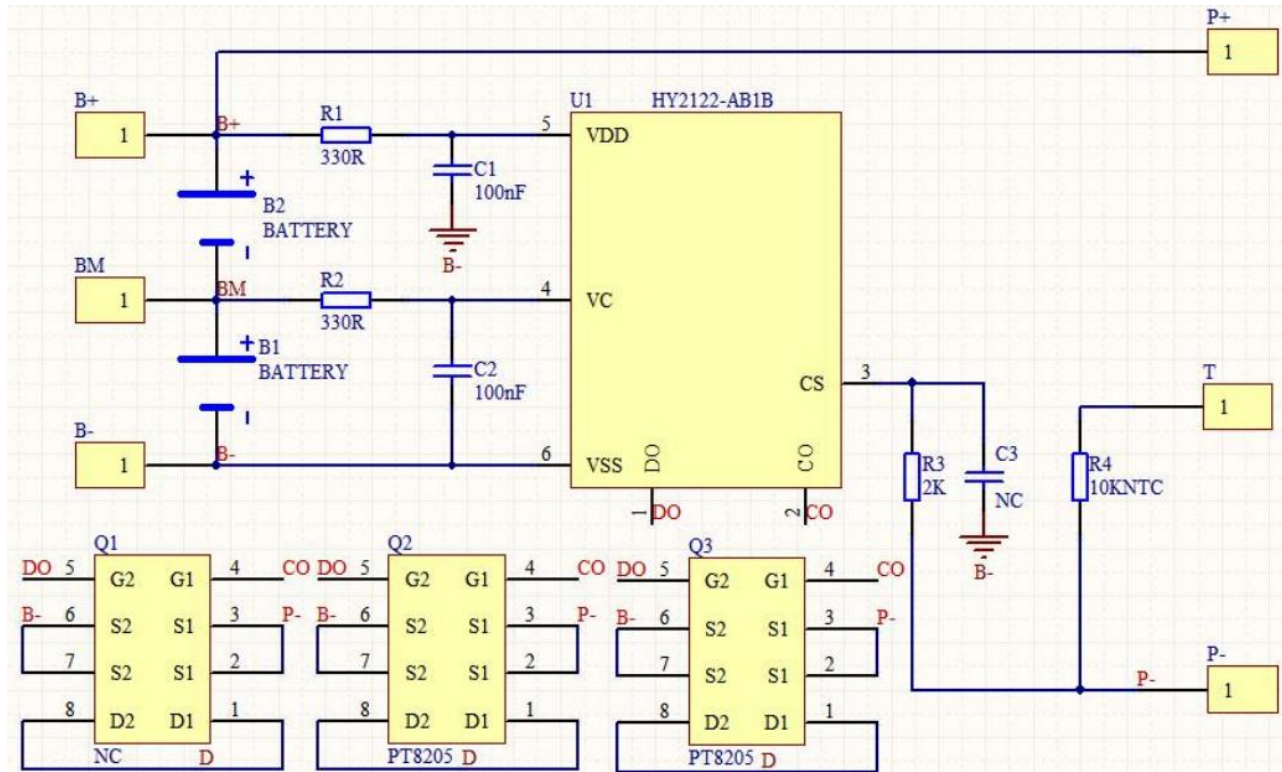

### 8 保护板元件清单 PCM BOM LIST

号位 Designator	名称 Name	规格 Specifications
	电路板 PCB	尺寸: 40.0*8.5*1.0mm, FR4, 双层板, 10Z 绿油白字 喷锡
U1	保护芯片 Protecion IC	HY2122-AB1B, SOT-23-6
U2 U3	NMOS	PT8205 TSSOP-8
R1 R2	贴片电阻	330R +/-5%,1/10W 0402
C1 C2	贴片电阻	100nF,±20%,25V,85C,0402
R3	贴片电阻	2K +/-5%,1/16W 0402
R4	NTC	10KNTC B=34351% 0402
BM B+ B-	镍片	4.0*3.0*0.3

HSZ	深圳市宏盛泽能源科技有限公司 <b>Shenzhen HSZ Energy Technology Co., Ltd</b>	文件编号:
	IFR18650-2000mAh-2S1P规格承认书	HSZ-SPE-RD-2380C

## 9 Handling Instructions 电池使用指南

Read and observe the following warnings and precautions to ensure correct and safe use of Li-ion batteries. 认真阅读下面的注意事项，确保正确使用锂离子电池。我司对违反下述注意事项而产生的任何问题不予负责。

### Danger! 危险!

Failure to observe the following precautions may result in battery leakage, overheating, explosion and/ or fire.

不仔细阅读下述事项可能导致电池泄露、爆炸或起火。

- Do not immerse the battery in water or allow it to get wet.
- 勿将电池投入水中或将其弄湿；
- Do not use or store the battery near sources of heat such as a fire or heater.
- 勿在热源（如火或加热器）附近使用或贮存电池；
- Do not use any chargers other than those recommended by HSZ.
- 请使用 HSZ 推荐的充电器；
- Do not reverse the positive (+) and negative (-) terminals.
- 勿将正负极接反；
- Do not connect the battery directly to wall outlets or car cigarette-lighter sockets.
- 勿将电池直接连接到墙上插座或车载点烟式插座上；
- Do not put the battery into a fire or apply direct heat to it.
- 勿将电池投入火中或给电池加热；
- Do not short-circuit the battery by connecting wires or other metal objects to the positive (+) and negative (-) terminals.
- 禁止用导线或其它金属物体将电池正负极短路；
- Do not carry or put the battery together with necklaces, hairpins or other metal objects.
- 禁止将电池和项链，发夹和其它金属物品放置在一起。
- Do not strike, throw or subject the battery near a fire or in extremely hot conditions.
- 禁止将电芯投放到较热的容器里。

### Warning! 警告!

Failure to observe the following precautions may result in battery leakage, overheating, explosion and/ or fire. 不仔细阅读下述事项可能导致电池泄露、爆炸或起火。

- Do not place the battery in a microwave oven or pressurized container.
- 禁止将电池置入微波炉或压力容器中；
- Do not use the battery in combination with primary batteries (such as dry-cell batteries) or batteries of different capacity, type or brand.
- 禁止与一次电池（如干电池）或不同容量、型号、品种电池组合使用；
- Do not use the battery if it gives off an odor, generates heat, becomes ct the battery to sever physical shock.
- 如果电池发出异味、发热、变形、变色或出现其它任何异常现象时不得使用；如果电池正在使用或充电，应立即从用电器中或充电器上取出并停止使用；
- Do not pierce the battery casing with a nail or other sharp object, break it open with a hammer, or step on it.
- 禁止用钉子或其它尖锐物体刺穿电池壳体，禁止锤击或脚踏电池；
- Do not directly solder the battery terminals. 禁止直接焊接电池端子。
- Do not attempt to disassemble or modify the battery in any way. 禁止以任何方式分解电池。
- Do not recharge discolored or deformed, or appears abnormal in any way. If the battery is in use or being recharged, remove it from the device or charger immediately and discontinue use.

HSZ	深圳市宏盛泽能源科技有限公司 <b>Shenzhen HSZ Energy Technology Co., Ltd</b>	文件编号:
	IFR18650-2000mAh-2S1P规格承认书	HSZ-SPE-RD-2380C

- 如果电池发出异味、发热、变形、变色或出现其它任何异常现象时不得使用；如果电池正在使用或充电，应立即从用电器中或充电器上取出并停止使用；
- Keep the batteries out of the reach of children. If a child somehow swallows a battery, seek medical attention immediately.
- 电池应放在小孩接触不到的地方，如果小孩不小心吞咽电池 应立即寻求医疗救助；
- If the battery leaks or emits an odor, immediately remove it from the proximity of any exposed flame. The leaking electrolyte can ignite and cause a fire or explosion.
- 如果电池泄漏或发出异味，应立即将其从接近明火处移开；泄漏的电解液可能引起火灾或爆炸；
- If the battery leaks and electrolyte gets in your eyes, do not rub them. Instead, rinse them with clean running water and immediately seek medical attention. If left as is, electrolyte can cause eye injury.
- 如果电池漏液后电解液进入眼睛，不要擦，应用水冲洗，立即寻求医疗救助。如不及时处理，眼睛将会受到伤害。

### Caution! 注意！

Do not use or store the battery where is exposed to extremely hot, such as under window of a car in direct sunlight in a hot day. Otherwise, the battery may be overheated. This can also reduce battery performance and/or shorten service life. 不要使用处于极热环境中的电池，如阳光直射或热天的车内。否则，电池会过热，可能着火（点燃）；同时这样也会影响电池的性能、缩短电池的使用寿命。

Use the battery only under the following environmental conditions. Failure to do so can result in reduced performance or a shorten service life. Recharging the battery outside of these temperatures can cause the battery to overheat, explode or catch fire. 只能在下述条件下使用电池，否则将会降低电池的性能或缩短电池的使用寿命。在此温度范围外使用电池可能引起过热、爆炸或起火。

The isolated measures are needed between battery (the bare Al layer at side and top sealing) and the PCB, and also between battery and electric equipment: especially avoid the Al layer in packing foil contact to cathode or anode (including electric equipment, otherwise this can cause battery leakage or swelling). 注意在电芯（侧边和极耳封边包装膜断口位置裸露的铝层）与保护板、及电芯与用电器具之间采用绝缘结构措施：特别注意避免出现包装膜铝层与正负极（包括用电器具的带电部分）出现接触的隐患，否则可能造成漏液气胀。

Operating environment 工作环境:

When charging the battery 电池充电温度: 10°C~45°C

When discharging the battery 电池放电温度: -10°C~45°C

When stored up to 30 days 存储 30 天: -10°C~45°C

When stored up to 90 days 存储 90 天: -10°C~35°C

The voltage for a long time (6 month) storage shall be 6.4-7.0V range. 超过 6 个月请及时进行充放一周后补电到 6.4-7.0V。

In cases where children use the battery, instruct them on the contents of the user's guide and keep an eye on them to ensure that the battery is being used correctly. 当小孩使用电池时，需要按用户说明书的内容教他们，并密切注意他们确保正确使用电池。

If the battery leaks and electrolyte gets your skin or clothing, immediately rinse the affected area with clean running water. If left as is, skin inflammation can occur. 如果电池漏液，电解液弄到皮肤或衣服上，立即用流动的水清洗受影响区域，否则可能导致皮肤发炎

HSZ	深圳市宏盛泽能源科技有限公司 <b>Shenzhen HSZ EnergyTechnology Co.,Ltd</b>	文件编号:
	IFR18650-2000mAh-2S1P规格承认书	HSZ-SPE-RD-2380C

For directions on battery installation and removal, read the instruction manual that accompanies the equipment in which the battery will be used. 阅读用电池的装置说明书，正确进行电池的安装与拆卸。

If a device is not used for an extended period, the battery should be removed and stored in a cool, dry place. Otherwise, resting or reduced performance may occur. 如果设备长期不用，将电池取出并放置在凉爽、干燥的地方，否则，电池可能生锈或性能变差。

If the terminals of the battery are dirty, wipe them clean with dry cloth before use. Otherwise, solid electrical contact may not be charged with the equipment, and this can cause power outages or charging to fail. 如果电池的端子变脏，使用前用干布擦干净。否则电池会接触不良，从而引起能量损耗或无法充电。

#### **10 Period of Warranty 保质期**

The period of warranty is a year from the date of shipment. HSZ guarantees to give a replacement in case of cells with defects proven due to manufacturing process instead of the customers' abuse and misuse.

电池的保质期为出厂后一年。本公司承诺如果在一年中由于电池本身的质量问题，本公司将负责进行调换，如果是由于用户误用而产生的问题，不予调换。

#### **11 Shipment 出货**

Cells in the factory has filling 80% of battery, the battery voltage 6.0-6.8V.

电池在出厂时已充入 40%左右的电量，电池电压 6.0-6.8V。

#### **12 Amendment of this Specification 产品规格书的修订**

This specification is subject to change with prior notice.

本公司有权对本产品规格书进行修订，在对产品规格书修订后我司将会通知客户。

HSZ	深圳市宏盛泽能源科技有限公司 <b>Shenzhen HSZ EnergyTechnology Co.,Ltd</b>	文件编号:
	IFR18650-2000mAh-2S1P规格承认书	HSZ-SPE-RD-2380C

外形尺寸图(单位: mm; 未按比例)

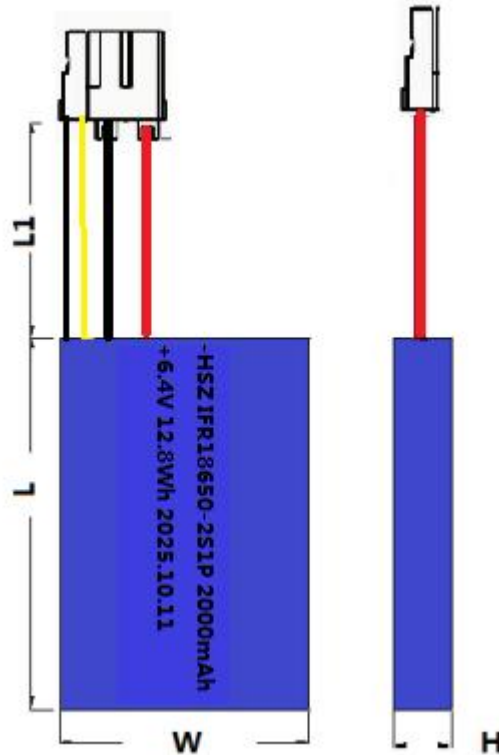

项目 Project	标准 Standard
电池长度 Battery length	$L \leq 67.2\text{mm}$
电池宽度 Battery width	$W \leq 37.2\text{mm}$
电池厚度 Battery thickness	$T \leq 20.5\text{mm}$
引线长度 Wire length	$L1: 85 \pm 5\text{mm}$ (外露)
导线规格 Wire specification	3239 18# 3239 24#
插头规格 Plug size	XT30(2+2)-F
黑色 EVA 尺寸 Black EVA size	出导线的一侧贴 $55*20*0.3\text{mm}$
小白盒尺寸 Small white box size	$25*45*75$
Connecting Wires: Red: connect to "+"; Black : connect to ground " - - "	
Yellow wire connected to "10kNTC"	
接线方式: 红线接正极, 黑线接负极, 黄线接 KNTC	