



UM0401

RTL872xD Datasheet

Realtek Confidential for 747632169@qq.com



Realtek Semiconductor Corp.

No. 2, Innovation Road II, Hsinchu Science Park, Hsinchu 300, Taiwan

Tel.: +886-3-578-0211. Fax: +886-3-577-6047

www.realtek.com

COPYRIGHT

©2021 Realtek Semiconductor Corp. All rights reserved. No part of this document may be reproduced, transmitted, transcribed, stored in a retrieval system, or translated into any language in any form or by any means without the written permission of Realtek Semiconductor Corp.

DISCLAIMER

Please Read Carefully:

Realtek Semiconductor Corp., (Realtek) reserves the right to make corrections, enhancements, improvements and other changes to its products and services. Buyers should obtain the latest relevant information before placing orders and should verify that such information is current and complete.

Reproduction of significant portions in Realtek data sheets is permissible only if reproduction is without alteration and is accompanied by all associated warranties, conditions, limitations, and notices. Realtek is not responsible or liable for such reproduced documentation. Information of third parties may be subject to additional restrictions.

Buyers and others who are developing systems that incorporate Realtek products (collectively, "Customers") understand and agree that Customers remain responsible for using their independent analysis, evaluation and judgment in designing their applications and that Customers have full and exclusive responsibility to assure the safety of Customers' applications and compliance of their applications (and of all Realtek products used in or for Customers' applications) with all applicable regulations, laws and other applicable requirements. Designer represents that, with respect to their applications, Customer has all the necessary expertise to create and implement safeguards that (1) anticipate dangerous consequences of failures, (2) monitor failures and their consequences, and (3) lessen the likelihood of failures that might cause harm and take appropriate actions. Customer agrees that prior to using or distributing any applications that include Realtek products, Customer will thoroughly test such applications and the functionality of such Realtek products as used in such applications.

Realtek's provision of technical, application or other design advice, quality characterization, reliability data or other services or information, including, but not limited to, reference designs and materials relating to evaluation kits, (collectively, "Resources") are intended to assist designers who are developing applications that incorporate Realtek products; by downloading, accessing or using Realtek's Resources in any way, Customer (individually or, if Customer is acting on behalf of a company, Customer's company) agrees to use any particular Realtek Resources solely for this purpose and subject to the terms of this Notice.

Realtek's provision of Realtek Resources does not expand or otherwise alter Realtek's applicable published warranties or warranty disclaimers for Realtek's products, and no additional obligations or liabilities arise from Realtek providing such Realtek Resources. Realtek reserves the right to make corrections, enhancements, improvements and other changes to its Realtek Resources. Realtek has not conducted any testing other than that specifically described in the published documentation for a particular Realtek Resource.

Customer is authorized to use, copy and modify any individual Realtek Resource only in connection with the development of applications that include the Realtek product(s) identified in such Realtek Resource. No other license, express or implied, by estoppel or otherwise to any other Realtek intellectual property right, and no license to any technology or intellectual property right of Realtek or any third party is granted herein, including but not limited to any patent right, copyright, mask work right, or other intellectual property right relating to any combination, machine, or process in which Realtek products or services are used. Information regarding or referencing third-party products or services does not constitute a license to use such products or services, or a warranty or endorsement thereof. Use of Realtek Resources may require a license from a third party under the patents or other intellectual property of the third party, or a license from Realtek under the patents or other Realtek's intellectual property.

Realtek's Resources are provided "as is" and with all faults. Realtek disclaims all other warranties or representations, express or implied, regarding resources or use thereof, including but not limited to accuracy or completeness, title, any epidemic failure warranty and any implied warranties of merchantability, fitness for a particular purpose, and non-infringement of any third party intellectual property rights.

Realtek shall not be liable for and shall not defend or indemnify Customer against any claim, including but not limited to any infringement claim that related to or is based on any combination of products even if described in Realtek Resources or otherwise. In no event shall Realtek be liable for any actual, direct, special, collateral, indirect, punitive, incidental, consequential or exemplary damages in connection with or arising out of Realtek's Resources or use thereof, and regardless of whether Realtek has been advised of the possibility of such damages. Realtek is not responsible for any failure to meet such industry standard requirements.

Where Realtek specifically promotes products as facilitating functional safety or as compliant with industry functional safety standards, such products are intended to help enable customers to design and create their own applications that meet applicable functional safety standards and requirements. Using products in an application does not by itself establish any safety features in the application. Customers must ensure compliance with safety-related requirements and standards applicable to their applications. Designer may not use any Realtek products in life-critical medical equipment unless authorized officers of the parties have executed a special contract specifically governing such use. Life-critical medical equipment is medical equipment where failure of such equipment would cause serious bodily injury or death. Such equipment includes, without limitation, all medical devices identified by the U.S.FDA as Class III devices and equivalent classifications outside the U.S.

Customers agree that it has the necessary expertise to select the product with the appropriate qualification designation for their applications and that proper product selection is at Customers' own risk. Customers are solely responsible for compliance with all legal and regulatory requirements in connection with such selection.

Customer will fully indemnify Realtek and its representatives against any damages, costs, losses, and/or liabilities arising out of Designer's non-compliance with the terms and provisions of this Notice.

TRADEMARKS

Realtek is a trademark of Realtek Semiconductor Corporation. Other names mentioned in this document are trademarks/registered trademarks of their respective owners.

USING THIS DOCUMENT

This document is intended for the software engineer's reference and provides detailed programming information.

Though every effort has been made to ensure that this document is current and accurate, more information may have become available subsequent to the production of this guide.

Realtek Confidential for 747632169@qq.com

Ordering Information

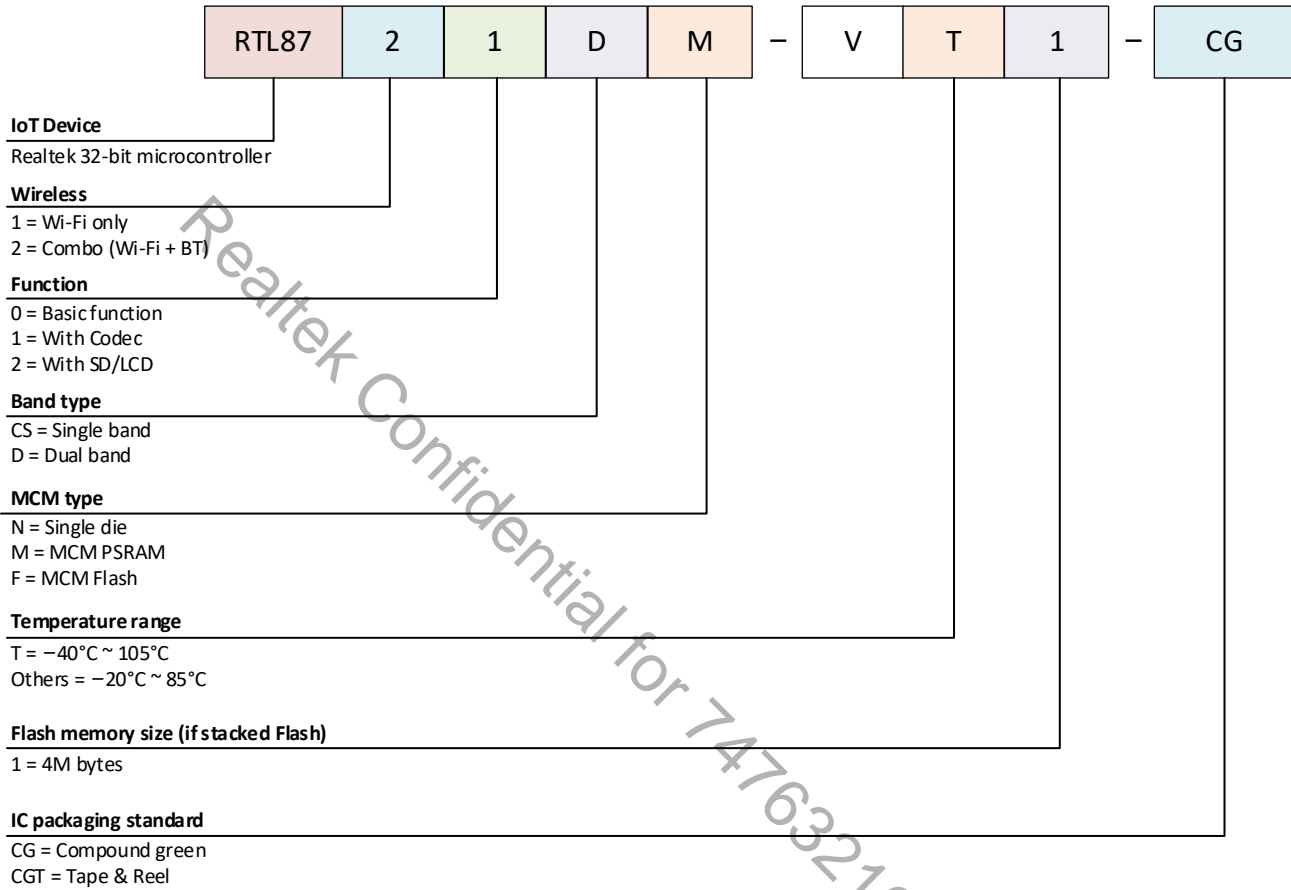

Part Number	Package	Status
RTL8720DN-VA1-CG	QFN48	MP
RTL8720DN-VA1-CGT	QFN48	tape-and-reel, MP
RTL8720DN-VT1-CG	QFN48	MP
RTL8720DM-VA1-CG	QFN48	MP
RTL8720DF-VA1-CG	QFN48	MP
RTL8720DF-VT1-CG	QFN48	MP
RTL8721DM-VA1-CG	QFN68	MP
RTL8721DM-VA1-CGT	QFN68	tape-and-reel, MP
RTL8722DM-VA1-CG	QFN88	MP
RTL8722DM-VA1-CGT	QFN88	tape-and-reel, MP

Contents

Ordering Information	4
Contents.....	5
1 Product Overview	8
1.1 General Description	8
1.2 System Architecture	8
1.3 Features	9
1.3.1 System and Memory	9
1.3.2 Wireless	10
1.3.3 Security	10
1.3.4 Communication Interface	10
1.3.5 Audio	12
1.3.6 Timer	13
1.3.7 Human-Machine Interaction	13
1.3.8 Analog	14
1.4 Package Comparison	14
1.4.1 Peripherals	14
1.4.2 Memory	15
2 Package	17
2.1 Package Types	17
2.1.1 QFN48	19
2.1.2 QFN68	21
2.1.3 QFN88	22
2.2 Low Power Pins	23
2.3 Pin Default Configuration	23
2.4 Trap Pins	23
3 Analog Pin Descriptions	25
3.1 Power on Trap Pin	25
3.2 RF Pins	25
3.3 Chip Enable Pin	25
3.4 Power Pins	25
3.5 XTAL Pins	26
3.6 ADC and Cap-Touch Pins	26
3.7 USB Pins	27
3.8 Audio Codec Pins	27
4 Memory Organization.....	28
4.1 Introduction.....	28
4.2 KM4 Memory.....	28
4.2.1 Memory Map and Register Boundary Addresses	28
4.2.2 Embedded SRAM	29

4.2.3	<i>Extension SRAM</i>	30
4.3	KMO Memory.....	30
4.3.1	<i>Memory Map and Register Boundary Addresses</i>	30
4.3.2	<i>Embedded SRAM</i>	30
4.4	Retention SRAM	30
4.5	SPI Flash Memory	31
4.6	PSRAM	31
5	Nested Vectored Interrupt Controller (NVIC)	32
5.1	Features.....	32
5.2	NVIC Diagram.....	32
5.3	NVIC Table	32
6	Radio Characteristics	35
6.1	RF Block Diagram.....	35
6.2	Wi-Fi Radio Characteristics.....	35
6.2.1	<i>Wi-Fi 2.4GHz Band RF Receiver Specifications</i>	35
6.2.2	<i>Wi-Fi 2.4GHz Band RF Transmitter Specifications</i>	36
6.2.3	<i>Wi-Fi 5GHz Band RF Receiver Specifications</i>	37
6.2.4	<i>Wi-Fi 5GHz Band RF Transmitter Specifications</i>	37
6.3	BT Radio Characteristics	38
6.3.1	<i>BT RF Transmitter Specifications</i>	38
6.3.2	<i>BT RF Receiver Specifications</i>	38
7	Electrical Characteristics	39
7.1	Temperature Limit Ratings	39
7.2	ESD Characteristics	39
7.3	DC Characteristics.....	39
7.3.1	<i>Power Supply</i>	39
7.3.2	<i>Digital I/O Pin</i>	40
7.4	ADC Characteristics	40
7.5	XTAL Oscillator.....	41
7.6	Power Consumption	42
7.7	Power State and Power Sequence.....	42
7.7.1	<i>Power on or Resuming from Deepsleep Sequence</i>	42
7.7.2	<i>Shutdown Sequence</i>	42
7.8	I/O Port Characteristics	43
7.8.1	<i>GPIO Sink and Source Current</i>	43
7.8.2	<i>GPIO Pull Low Restriction</i>	44
8	Package Specifications	45
8.1	QFN48.....	45
8.2	QFN68.....	46
8.3	QFN88.....	47
	List of Tables	49
	List of Figures	50

Revision History.....51

Realtek Confidential for 747632169@qq.com

1 Product Overview

1.1 General Description

RTL872xD is a highly integrated single-chip low power dual bands (2.4GHz and 5GHz) Wireless LAN (WLAN) and Bluetooth Low Energy (BLE 5.0) communication controller. It consists of a high performance MCU (Armv8-M, Cortex-M33 instruction set compatible) called Real-M300 (or KM4 thereafter) and a low power MCU (Armv8-M, Cortex-M23 instruction set compatible) called Real-M200 (or KM0 thereafter), WLAN (802.11 a/b/g/n) MAC, an 1T1R capable WLAN baseband, RF, Bluetooth and peripherals.

High speed connectivity interfaces, SDIO and USB are provided. There are also audio codec, Key-Scan and touch keys integrated into this IC. Besides, flexible design configures GPIO to different functions according to applications.

RTL872xD also integrates memories (ROM/SRAM/PSRAM) for IoT (Internet of Things) Wi-Fi protocol functions and applications. The user-friendly development kits (SDK and HDK) are supported to customers for developing IoT applications.

The KM4 MCU is a 32-bit core that offers system enhancements such as low power consumption, enhanced debug features, floating point computation, DSP instructions and a high level of support block integration. The KM4 MCU incorporates a 3-stage pipeline.

The KM0 coprocessor is an energy-efficient and easy-to-use 32-bit core which is code- and tool-compatible with the KM4 core. The KM0 coprocessor offers up to 20MHz performance with a simple instruction set and reduced code size.

1.2 System Architecture

The system architecture of RTL872xD is shown in Figure 1-1.

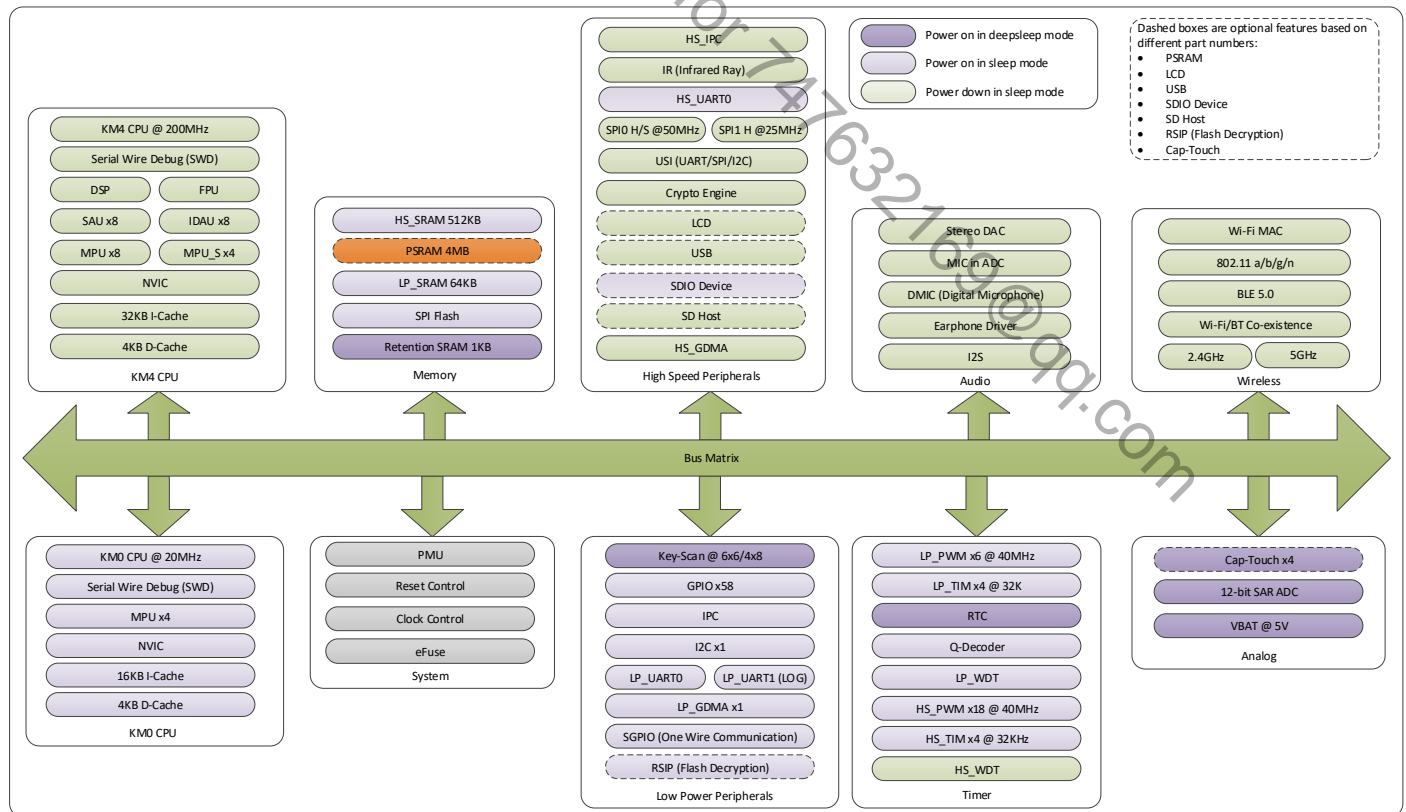

Figure 1-1 System architecture

In RTL872xD, the main system consists of 32-bit multilayer AXI bus matrix that interconnects all the masters and the slaves. The bus matrix provides access from a master to a slave, enabling concurrent access and efficient operation even when several high-speed peripherals work simultaneously.

A multilayer AXI bus matrix connects the CPU buses and other bus masters to peripherals in a flexible manner that optimizes performance by allowing peripherals on different slave ports of the matrix to be accessed simultaneously by different bus masters.

APB peripherals are connected to the AXI bus matrix via APB buses using separate slave ports from the multilayer AXI bus matrix. This allows for better performance by reducing collisions between the CPU and the DMA controller, and also for peripherals on the asynchronous bridge to have a fixed clock that does not track the system clock.

1.3 Features

1.3.1 System and Memory

The system and memory features of RTL872xD are listed in Table 1-1.

Table 1-1 System and memory features

Items	Description
Processor	<ul style="list-style-type: none"> ● Dual processor core ● KM4: Armv8-M architecture with Cortex-M33 instruction set compatible ● KM0: Armv8-M architecture with Cortex-M23 instruction set compatible ● Equal access to address space including SRAM, peripherals and registers
KM4 CPU	<ul style="list-style-type: none"> ● Cortex-M33 instruction set compatible <ul style="list-style-type: none"> ■ Floating Point Unit (FPU) ■ DSP ■ TrustZone-M ● Running at a frequency of up to 200MHz (configurable) ● Memory Protection Unit (MPU) ● Built-in Nested Vectored Interrupt Controller (NVIC) ● Non-maskable Interrupt (NMI) with a selection of sources ● Serial Wire Debug (SWD) with 8 break points and 4 watch points (without Serial Wire Output (SWO) for enhanced debug capabilities) ● System tick timer ● 32KB I-Cache and 4KB D-Cache
KM0 CPU	<ul style="list-style-type: none"> ● Cortex-M23 instruction set compatible ● Running at a frequency of up to 20MHz ● Built-in Nested Vectored Interrupt Controller (NVIC) ● Non-maskable Interrupt (NMI) with a selection of sources ● SWD with 4 break points and 2 watch points ● System tick timer ● 16KB I-Cache and 4KB D-Cache
KM4 CPU On-Chip memory	<ul style="list-style-type: none"> ● Up to 512KB contiguous main SRAM @200MHz ● Optional 4MB PSRAM @ 50MHz, 8-bit DDR, refer to 1.4.2
KM0 CPU On-Chip memory	<ul style="list-style-type: none"> ● Up to 64KB contiguous main SRAM ● Up to 1KB retention SRAM for keeping data in power saving modes
GDMA	<ul style="list-style-type: none"> ● KM4 and KM0 both have a GDMA controller ● HS-GDMA0 supports six channels with TrustZone-M ● LP-GDMA0 supports six channels without TrustZone-M
Flash	<ul style="list-style-type: none"> ● Optional internal 4M bytes (32M bits) Flash, refer to 1.4.2 ● SPI/DSPI/QSPI¹ Flash controller with cache ● Flash In-Circuit Programming (ICP) supported
General-Purpose I/O (GPIO)	<ul style="list-style-type: none"> ● Up to 64 General-Purpose I/O (GPIO) pins. All GPIOs have configurable pull-up/pull-down resistors. ● GPIO interrupt trigger could be configured with rising, falling or both input edges.
IPC	Inter-Processor communication

1. Only QFN88 supports QSPI, while QFN48 and QFN68 just support SPI/DSPI.

1.3.2 Wireless

The wireless features of RTL872xD are listed in Table 1-2.

Table 1-2 Wireless features

Items	Description
Wi-Fi	<ul style="list-style-type: none"> ● 802.11 a/b/g/n 1x1, 2.4GHz & 5GHz ● Supports 20MHz/40MHz up to MCS7 ● Low power architecture ● Low power Tx/Rx for short range application @1.8V ● Low power beacon listen mode ● Low power Rx mode ● Very low power suspends mode (DLPS) ● Built-in PA, also supports external PA and LNA ● Supports Antenna diversity ● Internal PTA interface for arbitrating data transmission between Wi-Fi and internal Bluetooth or external 2.4G devices
Bluetooth	<ul style="list-style-type: none"> ● BLE 5.0 ● Both central and peripheral modes ● High power mode (8dbm, shares the same PA with Wi-Fi) ● Internal co-existence mechanism between Wi-Fi and BT to share the same antenna

1.3.3 Security

The Security features of RTL872xD are listed in Table 1-3.

Table 1-3 Security features

Items	Description
Hardware engine	AES/DES/SHA hardware engine
TrustZone	TrustZone-M supported
Secure boot	Secure boot supported
SWD protection	Debug port access protection and prohibition modes
eFuse protection	Secure eFuse
RSIP	Flash decryption on-the-fly

1.3.4 Communication Interface

The communication interface features of RTL872xD are listed in Table 1-4.

Table 1-4 Communication interface features

Items	Description
SD/SDIO	<ul style="list-style-type: none"> ● SD card host supported ● SDIO 2.0 SDR25 supported ● Realtek SPI provides high efficiency SPI interface with interrupt and full duplex mode ● SDIO inic mode (SDIO to Wi-Fi transformation) ● Clock rate variable up to 50MHz ● Internal DMA supported ● SDIO device time consuming from power on to initialization completion: 64.14635ms
USB	<ul style="list-style-type: none"> ● USB 2.0 ● HS/FS/LS mode ● Internal DMA support, DMA works based on register settings ● 1.5KByte bulk-in buffer and 1.5KByte bulk-out buffer
SPI	<ul style="list-style-type: none"> ● Motorola SPI Serial interface operation supported ● Master or slave operation mode supported ● Providing two SPI ports: <ul style="list-style-type: none"> ■ SPI0 (High speed): configured as master or slave with Max. baud rate: 50MHz.

	<ul style="list-style-type: none"> ■ SPI1 (Normal speed): configured as master with Max. baud rate: 25MHz. ● DMA interface for DMA transfer supported ● Independent masking of interrupts ● FIFO depth – The transmit and receive FIFO buffers 64 words deep. The FIFO width is fixed at 16 bits. ● Hardware/software slave-select – Dedicated hardware slave-select lines can be used or software control can be used to target the serial-slave device ● Programmable features: <ul style="list-style-type: none"> ■ Clock bit-rate – Dynamic control of the serial bit rate of the data transfer; used in only serial-master mode of operation. ■ Data item size (4 to 16 bits) – Item size of each data transfer under the control of the programmer. ■ Configurable clock polarity and phase ■ Programmable delay on the sample time of the received serial data bit (rxd), when configured in Master Mode; enables programmable control of routing delays resulting in higher serial data-bit rates.
UART (HS_UART/LP_UART)	<ul style="list-style-type: none"> ● UART format: 1 start bit, 7/8 data bits, 0/1 parity bit and 1/2 stop bit ● Support up to 6MHz baud rate ● Auto flow control supported ● Interrupt control supported ● IrDA supported ● Loopback mode for test ● Fractional baud rate generator ● Low power mode for Rx path ● Monitor and eliminate Rx baud rate error and own frequency drift automatically for Rx path ● DMA mode supported <ul style="list-style-type: none"> ■ LP_UART: DMA mode on KM4 platform not supported ● Option for UART Rx to be DMA flow controller
IR (Infra Ray)	<ul style="list-style-type: none"> ● Carrier frequency from 25kHz to 500kHz ● Duty from 1/2 to 1/5 ● IR diode input supported ● IR receiver module input supported ● 32*4 bytes Tx FIFO ● 32*4 bytes Rx FIFO ● Tx carrier frequency can be configured ● Tx carrier duty cycle can be configured
One wire (SGPIO)	<ul style="list-style-type: none"> ● One wire communication interface for security element ● Timer Mode: <ul style="list-style-type: none"> ■ Rx and Multiple Timer are 16-bit timer with a 16-bit prescaler. ■ Rx and Multiple Timer can stop, reset, and interrupt by match events. ■ Rx and multiple timer/counter can stop and reset to each other. ● Capture Mode: <ul style="list-style-type: none"> ■ Rx timer can be captured by capture events. ■ Capture events can be Rx trigger events or the multiple match events. ■ The capture value can be transferred to '0' or '1' by comparing the value. ● Counter Mode: <ul style="list-style-type: none"> ■ Multiple Counter can count Rx trigger events. ● External Output Mode: <ul style="list-style-type: none"> ■ External output can set high, low or toggle on the match event. ● Get the serial input: <ul style="list-style-type: none"> ■ Shift the input value to a 32-bit FIFO by match events. ● Send the serial output: <ul style="list-style-type: none"> ■ Send the '0' or '1' waveform by shifting the output value of a 32-bit FIFO. This output value decides that the external match uses the match value of group 0 or group 1. ■ Change the output value by using the multiple FIFO data to update the multiple match value. ● Monitor Mode: <ul style="list-style-type: none"> ■ Monitor the receiving value to make the interrupt in the power saving mode.
I ² C	<ul style="list-style-type: none"> ● Two-wire I²C serial interface – consists of a serial data line (SDA) and a serial clock (SCL)

	<ul style="list-style-type: none"> ● One I²C port supported ● Two Speed mode: <ul style="list-style-type: none"> ■ Standard (up to 100Kbps) ■ Fast (up to 400Kbps) ● Master or Slave I²C operation ● 7- or 10-bit addressing ● Transmit and receive buffers with depth of 16 ● Tx and Rx DMA support ● Multi-master ability including bus arbitration scheme ● Slave mode address match wakeup for power save (up to 100Kbps) ● Clock stretch in master/slave mode ● 7- or 10-bit combined format transfers ● General Call ● Component parameters for configurable software driver support (programmable SDA hold time, slave address, etc.) ● Filter to eliminate the glitches on signal of SDA and SCL. Programmable digital noise Filter. ● Status flags (Bus busy flag, activity flag, FIFO status flag, etc.) and Error flags (arbitration lost, acknowledge failure, etc.)
USI (Universal Serial interface)	<ul style="list-style-type: none"> ● Configured as SPI, UART or I²C ● USI I²C can support High Speed Mode

1.3.5 Audio

The audio features of RTL872xD are listed in Table 1-5.

Table 1-5 Audio features

Items	Description
Audio DAC and earphone driver	<ul style="list-style-type: none"> ● Sampling Frequency: 8/16/32/44.1/48/88.2/96kHz ● Integrates earphone driver <ul style="list-style-type: none"> ■ 40mW on 16Ω load ■ 20mW on 32Ω load ● Gain Control in DAC Path <ul style="list-style-type: none"> ■ Gain Step: 0.375dB/step ■ Gain Range: -64.5dB ~ 0dB ● Audio output mode <ul style="list-style-type: none"> ■ Line-Out Cap-less mode (QFN88) ■ Line-Out Differential mode (QFN88) ■ Line-Out Single-ended mode
Audio ADC	<ul style="list-style-type: none"> ● Sampling Frequency: 8/16/32/44.1/48/88.2/96kHz ● ADC input gain range <ul style="list-style-type: none"> ■ Gain Step: 0.375dB/step ■ Gain Range: -17.625dB ~ 30dB (digital) ● MIC input boost gain stage: 0/20/30/40dB (analog) ● Audio input mode <ul style="list-style-type: none"> ■ Line-In ■ Analog MICx2 or Digital MIC x2
I ² S	<ul style="list-style-type: none"> ● Sample rate <ul style="list-style-type: none"> ■ 8/12/16/24/32/48/64/96/192/384/7.35/11.025/14.7/22.05/29.4/44.1/58.8/88.2/176.4kHz ● I²S channel number <ul style="list-style-type: none"> ■ mono ■ stereo ■ 5.1 channel ● Sample bit for mono <ul style="list-style-type: none"> ■ 16-bit ■ 32-bit ● Sample bit for stereo & 5.1 channel <ul style="list-style-type: none"> ■ 16-bit

	<ul style="list-style-type: none"> ■ 24-bit ■ 32-bit ● Integrated DMA engine to minimize the software efforts ● Mono and stereo Tx or Rx, or Tx & Rx mode ● 5.1 Tx mode (DAC) supported, Rx mode (ADC) not supported ● PCM mode not supported
--	---

1.3.6 Timer

The timer features of RTL872xD are listed in Table 1-6.

Table 1-6 Timer features

Items	Description
Basic Timers (HS_TIM0 ~ HS_TIM3) (LP_TIM0 ~ LP_TIM3)	<ul style="list-style-type: none"> ● Channels: x1 ● Clock source: 32kHz ● Resolution: 32-bit ● Counter mode: up ● Interrupt generation ● Sleep mode wakeup
PWM Timers (HS_TIM5 & LP_TIM5)	<ul style="list-style-type: none"> ● Channels: HS_TIM5 x18, LP_TIM5 x6 ● Clock source: XTAL ● Resolution: 16-bit ● Prescaler: 8-bit ● Counter mode: up ● Statistics pulse width ● Statistics pulse counter ● Input capture pin: x2 ● Interrupt generation ● LP_TIM5 can work at sleep mode
Pulse Timers (HS_TIM4 & LP_TIM4)	<ul style="list-style-type: none"> ● Channels: HS_TIM5 x18, LP_TIM5 x6 ● Clock source: XTAL ● Resolution: 16-bit ● Prescaler: 8-bit ● Counter mode: up ● One pulse mode ● PWM mode with polarity selection ● Input capture pin: x2 ● Interrupt generation
Real-Time clock (RTC)	<ul style="list-style-type: none"> ● Independent BCD timer/counter ● Time with seconds, minutes, hours, days (12- or 24-hour format) ● Daylight saving compensation programmable by software ● One programmable alarm with interrupt function. The alarm can be triggered by any combination of the time fields. ● Maskable interrupts/events <ul style="list-style-type: none"> ■ Alarm ● Digital calibration circuit ● Register write protection

1.3.7 Human-Machine Interaction

The human-machine interaction (HMI) features of RTL872xD are listed in Table 1-7.

Table 1-7 Human- machine interaction features

Items	Description
Key-matrix	<ul style="list-style-type: none"> ● Up to 8*8 (64) Keypad Array with use of 16 GPIOs ● Configurable Rows and Columns of Keypad Array

	<ul style="list-style-type: none"> ● Hardware debounce with configurable time at each scan ● Configurable Scan Clock, Scan Interval and Release Time ● Support interrupts, provide interrupts mask, interrupts clear, interrupts status ● Multi-keys detect ● FIFO with width of 12 bits and depth of 16 to store Key Press and Release Events ● Low power mode. Key press event can wakeup CPU from sleep.
Cap-Touch	<ul style="list-style-type: none"> ● 4 capacitive sensor channels ● Automatic channel scan: hardware scan each enabled channel automatically in sequence ● Programmable scan period: sample number and scan interval ● Difference or Absolute threshold judgement mode (with ETC function enable) <ul style="list-style-type: none"> ■ Automatic environment sensor capacitance tracking and calibration (ETC) ■ Hardware baseline initial automatically ● Automatic baseline and threshold update for different noise environment ● Programmable button debounce function ● Programmable interrupt enabled for each interrupt source ● 4*12 bits FIFO ● Low power consumption
LCD	<ul style="list-style-type: none"> ● Thin Film Transistor (TFT) color display ● 8-bit MCU I8080 parallel interface <ul style="list-style-type: none"> ■ Resolution of 8-bit mode, (1024x1024) for still picture display ■ Resolution of 8-bit mode, (645x645) for dynamic display when refresh rate is 30F/S ● 6-bit RGB parallel interface <ul style="list-style-type: none"> ■ Resolution of 6-bit mode, less than (527x527) for dynamic display when refresh rate is 60F/S ● RGB565 data format for input & output ● Programmable timings for different display panels ● Programmable polarity for HSYNC, VSYNC and Data Enable ● DMA frame buffer for RGB/MCU I/F ● I/O mode for MCU I/F

1.3.8 Analog

The analog features of RTL872xD are listed in Table 1-8.

Table 1-8 Analog features

Items	Description
Data capture ADC and voltage comparator	<ul style="list-style-type: none"> ● Resolution: 12-bit SAR ● Available channel number <ul style="list-style-type: none"> ■ 7x external 3.3V channel and 1x 5V channel ■ 3x internal channel ● Configurable input <ul style="list-style-type: none"> ■ Single-ended ■ Differential with predefined channel pair ● Contain 64 FIFO entries which is 16-bit width ● Multi-Channel DMA support ● Multi sampling trigger sources <ul style="list-style-type: none"> ■ Software ■ Timer ● 1 low power voltage comparator for battery voltage measurement ● Conversion item control or another FIFO level to trigger wakeup circuit

1.4 Package Comparison

1.4.1 Peripherals

The peripherals of RTL872xD under different packages are shown in Table 1-9.

Table 1-9 Peripherals under different packages

Item	Peripheral	Description	QFN48		QFN68	QFN88
			RTL8720DN RTL8720DM	RTL8720DF	RTL8721DM	RTL8722DM
UART	HS_UART0		-	✓	✓	✓
	HS_USI_UART		✓	✓	-	✓
	LP_UART1	Low power mode wakeup	✓	✓	✓	✓
	LP_UART0	LOGUART/low power mode wakeup	✓	✓	✓	✓
SPI	HS_SPI0	Maximum 50MHz, Master/Slave	-	✓	✓	✓
	HS_SPI1	Maximum 25MHz, Master	✓	✓	✓	✓
	HS_USI_SPI	Maximum 25MHz, Master/Slave	✓	✓	✓	✓
RTC	RTC_OUT		✓	✓	✓	✓
	EXT_32K		✓	✓	✓	✓
	LP_TIM4_TRIG	Timer capture	-	✓	✓	✓
	LP_TIM5_TRIG	Timer capture	-	✓	✓	✓
IR	IR		✓	✓	✓	✓
I ² C	LP_I ² C	Standard (up to 100Kbps) Fast (up to 400Kbps)	✓	✓	✓	✓
	HS_USI_I2C	Standard/fast/high speed mode (up to 3.33Mbps)	✓	✓	-	✓
SDIO	SDIO 2.0 Device	Maximum 50MHz	-	-	-	✓
	SD HOST	Maximum 50MHz	-	✓	-	✓
PWM	HS_PWM0 ~ 17		8	13	11	17
	LP_PWM0 ~ 5	Low power mode	4	6	6	6
I ² S	I ² S			✓	✓	✓
DMIC	DMIC		✓	-	✓	✓
LCD	LCD	8-bit/16-bit/RGB mode MCU mode LED mode	-	-	-	✓
Q-Decoder	Q-Decoder		-	✓	✓	✓
SGPIO	SGPIO		✓		✓	✓
Key-Scan	Key-Scan		5x2/4x3	5x2/4x3	7x3/5x5	4x8/6x6
Wake Pin	Wake Pin	Wakeup from deepsleep	7	7	10	12
HS Timer	HS_TIM4_TRIG	Timer capture	✓	✓	✓	✓
	HS_TIM5_TRIG	Timer capture	✓	-	✓	✓
Analog Pin	USB	USB host or device (selectable)	✓	✓	✓	✓
	ADC	0 ~ 3.3V	x3	x2	x7	x7
	VBAT_MEAS	0 ~ 5V	-	✓	✓	✓
	Cap-Touch		-	-	x4	x4
	Audio Output	Analog audio codec output	-	-	x2 (Single-ended)	x2 (Differential)/ x2 (Single-ended) x2 (AUXIN)
	Audio Input	Analog audio codec input	-	-	x2 (Single-ended)	x1 (Differential)/ x2 (Single-ended) x2 (AUXIN)

1.4.2 Memory

The memory of RTL872xD under different packages are shown in Table 1-10.

Table 1-10 Memory under different packages

Item	QFN48			QFN68	QFN88
	RTL8720DN	RTL8720DM	RTL8720DF	RTL8721DM	RTL8722DM
Internal Flash	-	-	4M bytes	-	-
PSRAM	-	4M bytes	-	4M bytes	4M bytes

Realtek Confidential for 747632169@qq.com

2 Package

2.1 Package Types

There are three package types named QFN48, QFN68 and QFN88 in RTL872xD, the details are shown in Table 2-1.

Table 2-1 Package types

Port Name	QFN48		QFN68	QFN88	Trap
	RTL8720DN RTL8720DM	RTL8720DF	RTL8721DM	RTL8722DM	
PA[0]			✓	✓	
PA[1]				✓	
PA[2]			✓	✓	
PA[3]					
PA[4]			✓	✓	
PA[5]				✓	
PA[6]				✓	
PA[7]	✓	✓	✓	✓	UART_DOWNLOAD
PA[8]	✓		✓	✓	
PA[9]				✓	
PA[10]				✓	
PA[11]				✓	
PA[12]	✓	✓	✓	✓	ICFG0
PA[13]	✓	✓	✓	✓	ICFG1
PA[14]	✓	✓	✓	✓	ICFG2
PA[15] ¹	✓	✓	✓	✓	ICFG3
PA[16] ¹	✓	✓		✓	
PA[17]				✓	
PA[18]			✓	✓	
PA[19]			✓	✓	
PA[20]				✓	
PA[21]				✓	
PA[22]				✓	
PA[23]				✓	
PA[24]				✓	
PA[25]	✓	✓	✓	✓	
PA[26]	✓	✓	✓	✓	
PA[27]	✓	✓	✓	✓	NORMAL_MODE_SEL
PA[28]	✓	✓	✓	✓	
PA[29]					
PA[30]	✓	✓	✓	✓	SPS_SEL
PA[31]				✓	
PB[0]				✓	
PB[1]	✓	✓	✓	✓	
PB[2]	✓		✓	✓	
PB[3]	✓	✓	✓	✓	
PB[4]			✓	✓	
PB[5]			✓	✓	
PB[6]			✓	✓	
PB[7]			✓	✓	
PB[8]					
PB[9]					
PB[10]					

PB[11]					
PB[12]				✓	
PB[13]	✓		✓	✓	
PB[14]	✓		✓	✓	
PB[15]				✓	
PB[16]	✓		✓	✓	
PB[17]	✓		✓	✓	
PB[18]		✓		✓	
PB[19]		✓		✓	
PB[20]	✓	✓		✓	
PB[21]	✓	✓		✓	
PB[22]		✓	✓	✓	
PB[23]		✓	✓	✓	
PB[24]					
PB[25]					
PB[26]			✓		
PB[27]					
PB[28]				✓	
PB[29]			✓	✓	
PB[30]				✓	
PB[31]			✓	✓	

- For QFN48, PA[15] & PA[16] are in the High-Z state by default, and they do not affect each other. It is recommended to choose one of PA[15] & PA[16] instead of using them at the same time.

Realtek Confidential for 747632169@qq.com

2.1.1 QFN48

The QFN48 pin assignments for RTL8720DN/RTL8720DM are shown in Figure 2-1.

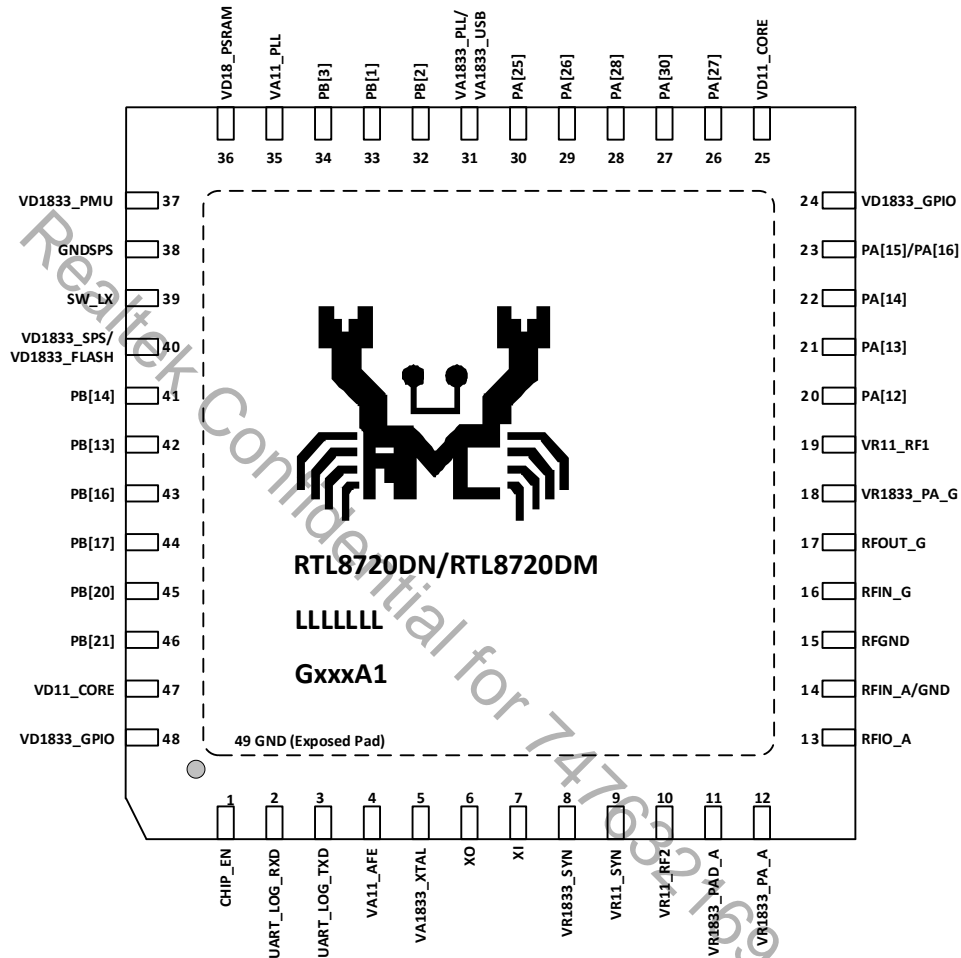

Note: For #23, PA[15] & PA[16] are in the High-Z state by default, and they do not affect each other. It is recommended to choose one of PA[15] & PA[16] instead of using them at the same time.

Figure 2-1 QFN48 pin assignments for RTL8720DN/RTL8720DM

The QFN48 pin assignments for RTL8720DF is shown in Figure 2-2.

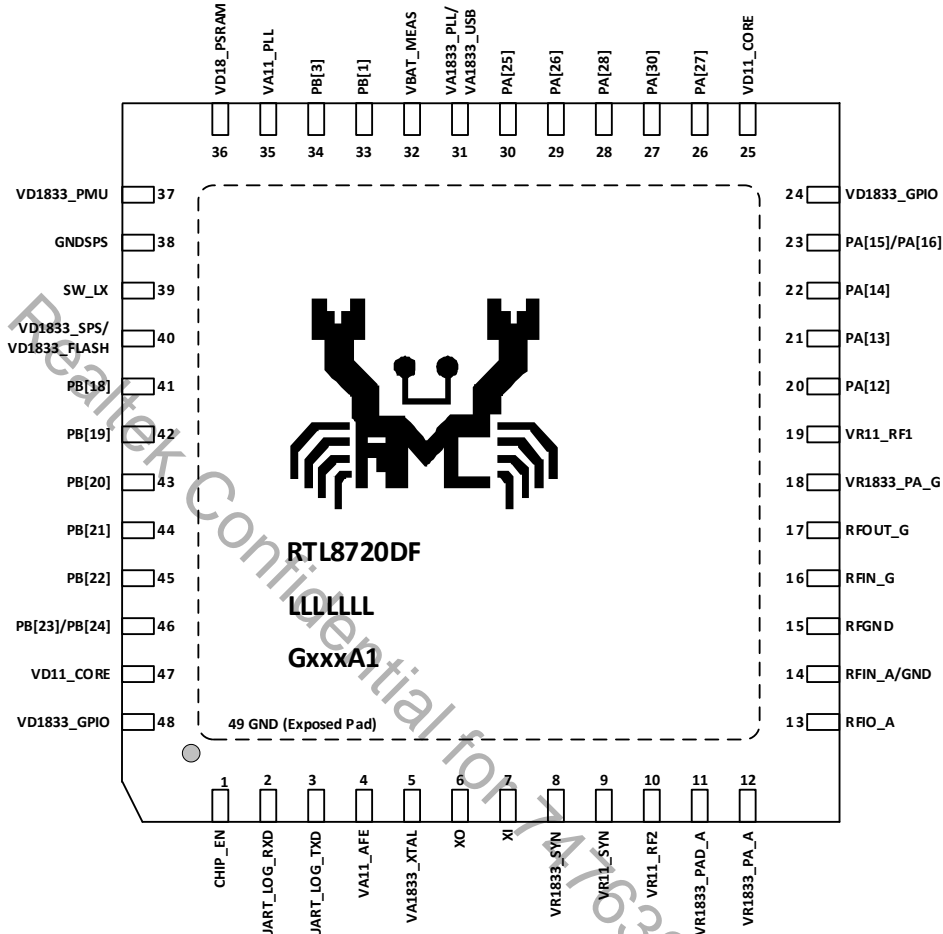

Note: For #23, PA[15] & PA[16] are in the High-Z state by default, and they do not affect each other. It is recommended to choose one of PA[15] & PA[16] instead of using them at the same time.

Figure 2-2 QFN48 pin assignments for RTL8720DF

2.1.2 QFN68

The QFN68 pin assignments for RTL8721DM are shown in Figure 2-3.

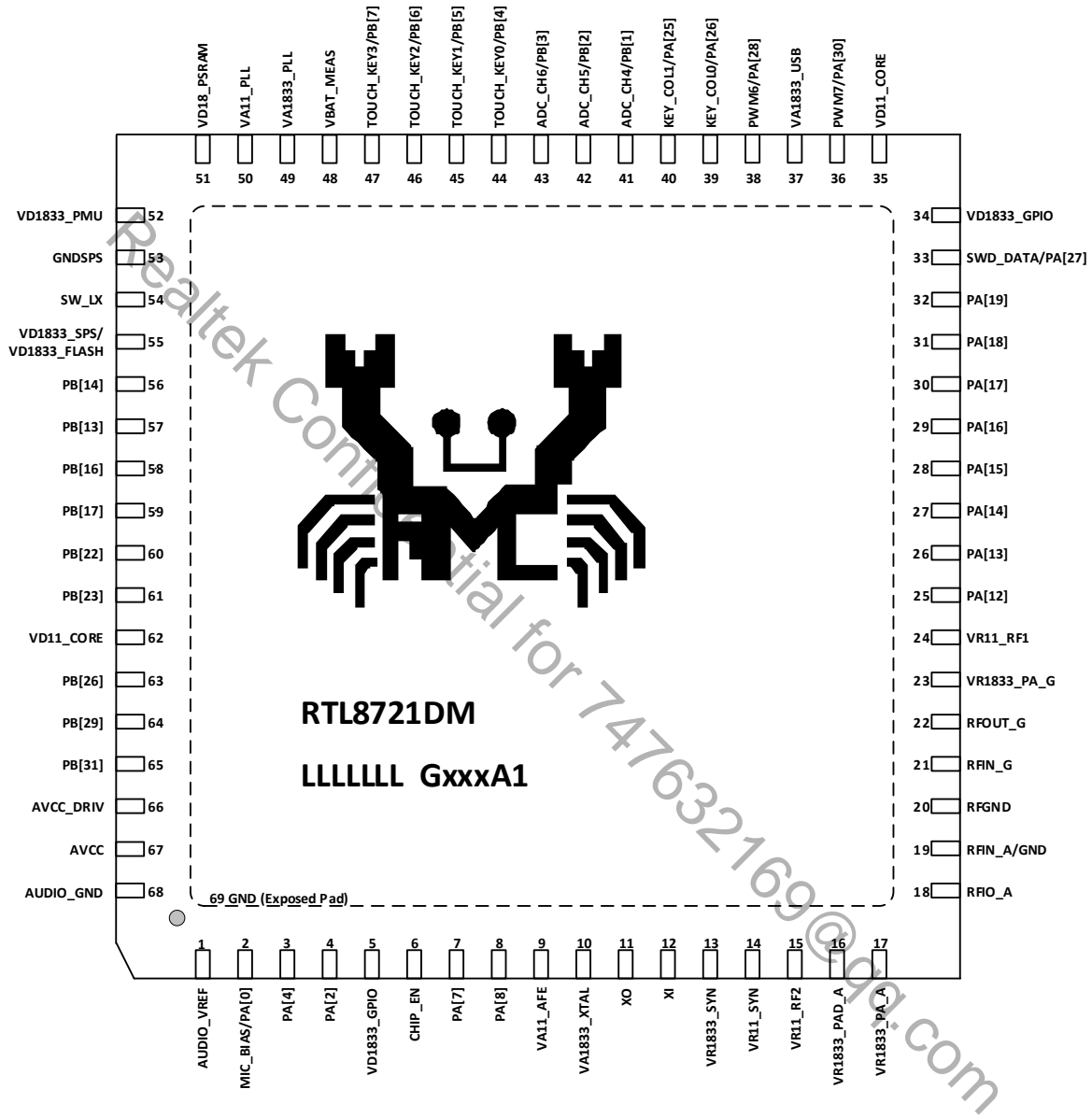

Figure 2-3 QFN68 pin assignment for RTL8721DM

2.1.3 QFN88

The QFN88 pin assignments for RTL8722DM are shown in Figure 2-4.

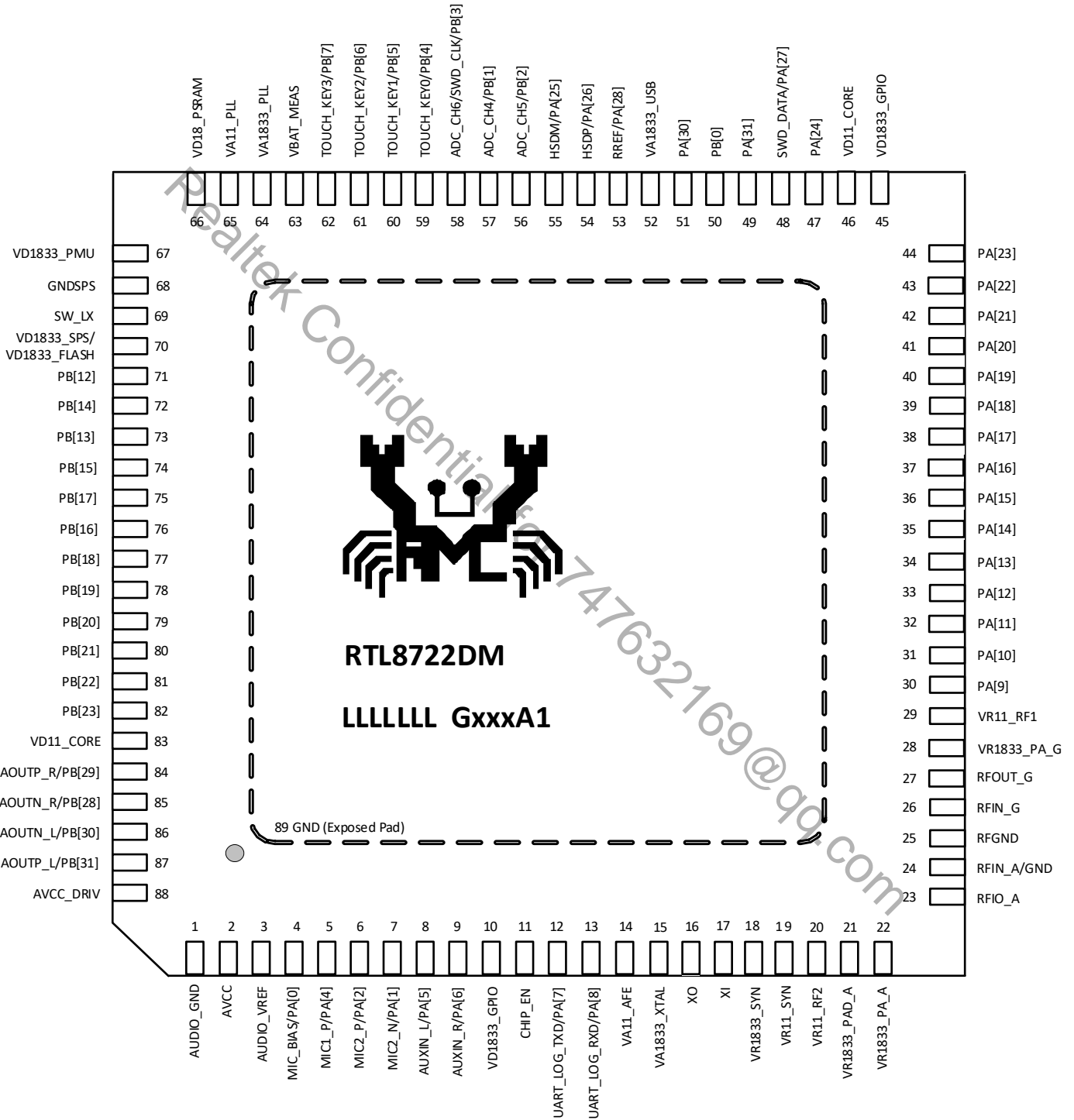

Figure 2-4 QFN88 pin assignments for RTL8722DM

2.2 Low Power Pins

These pins can work and wakeup MCU under deepsleep mode, as Table 2-2 shows. All these pins are located at Key-Scan pins.

Table 2-2 Low power pins

Pin Name/GPIO	Ext32K	Key-Scan Row	Key-Scan Column	Wakeup
PA[12]		KEY_ROW0		LGPIO[0]
PA[13]		KEY_ROW1		LGPIO[1]
PA[14]	RTC_OUT	KEY_ROW2		LGPIO[2]
PA[15]	RTC_EXT_32K	KEY_ROW3	KEY_COL6	LGPIO[3]
PA[16]		KEY_ROW4	KEY_COL5	LGPIO[0]
PA[17]		KEY_ROW6	KEY_COL3	LGPIO[1]
PA[18]	RTC_OUT	KEY_ROW5	KEY_COL4	LGPIO[2]
PA[19]			KEY_COL2	LGPIO[3]
PA[20]			KEY_COL7	LGPIO[0]
PA[21]		KEY_ROW7		LGPIO[1]
PA[25]			KEY_COL1	LGPIO[2]
PA[26]			KEY_COL0	LGPIO[3]

2.3 Pin Default Configuration

All pins are configured as GPIO without pull resistors except some special function like SWD or LOGUART. The pin default configuration is listed in Table 2-3.

Table 2-3 Pin default configuration

Pin Name	Default Function	Default PU/PD
PA[7]	LOGUART	Internal UP
PA[8]	LOGUART	Internal UP
PA[13]	PA[13]	eFuse Pull Control 0
PA[15]	PA[15]	eFuse Pull Control 1
PA[25]	PA[25]	eFuse Pull Control 2
PA[27] ¹	SWD_DATA when eFuse enable	Internal UP
PA[28]	PA[28]	eFuse Pull Control 3
PA[30]	PA[30]	External UP
PB[1]	PB[1]	eFuse Pull Control 4
PB[3] ¹	SWD_CLK when eFuse enable	No pull
PB[7]	PB[7]	eFuse Pull Control 5
PB[18] ²	SWD_CLK when eFuse enable, or SD_D2 when eFuse enable SDIO	No pull
PB[19] ²	SWD_DATA when eFuse enable, or SD_D3 when eFuse enable SDIO	eFuse Pull Control 6
PB[20]	SD_CMD when eFuse enable SDIO	No pull
PB[21]	SD_CLK when eFuse enable SDIO	No pull
PB[22]	SD_D0 when eFuse enable SDIO	eFuse Pull Control 7
PB[23]	SD_D1 when eFuse enable SDIO	No pull

NOTE

- When bit[0] of logical eFuse 0x0e is '1' by default, PA[27] and PB[3] are used for SWD function, and PA[27] is internal pull up.
- When bit[0] of logical eFuse 0x0e is programmed to '0', PB[18] and PB[19] are used for SWD function, and PB[19] is internal pull up.

2.4 Trap Pins

The trap pins are listed in Table 2-4.

Table 2-4 Trap pins

Pin Name	Trap Function	Description
PA[7]	UART_DOWNLOAD	Trigger ISP ROM code Flash download, low active.
PA[12]	ICFG0	Realtek test mode
PA[13]	ICFG1	Realtek test mode
PA[14]	ICFG2	Realtek test mode
PA[15]	ICFG3	Realtek test mode
PA[27]	NORMAL_MODE_SEL	It is not allowed to pull down when power on, otherwise: <ul style="list-style-type: none"> ● Realtek test mode will be selected. ● Boot will fail. When this pin is not pull-down, the state of PA[12] ~ PA[15] can be ignored.
PA[30]	SPS_SEL	<ul style="list-style-type: none"> ● 1: Internal 1.1V regulator works at SPS mode ● 0: Internal 1.1V regulator works at LDO mode

Realtek Confidential for 747632169@qq.com

3 Analog Pin Descriptions

The signal type used in RTL872xD are shown in Table 3-1.

Table 3-1 Pin type description

Symbol	Type	Symbol	Type
I	Input pin	O	Output pin
P	Power pin	AH	Analog and digital hybrid programmable pin
PI	Power input pin	PO	Power Output pin

3.1 Power on Trap Pin

The power on trap pins in RTL872xD are shown in Table 3-2.

Table 3-2 Power on trap pins

Symbol	Type	QFN48	QFN68	QFN88	Description
NORMAL_MODE_SEL	I	26	33	48	Shared with PA[27] <ul style="list-style-type: none"> ● 1: Normal operation mode ● 0: Enter into test/debug mode
UART_DOWNLOAD	I	3	7	12	Shared with PA[7] <ul style="list-style-type: none"> ● 1: Boot from Flash ● 0: Download image from UART
SPS_SEL	I	27	36	51	Shared with PA[30] <ul style="list-style-type: none"> ● 1: Internal 1.1V regulator works at SPS mode ● 0: Internal 1.1V regulator works at LDO mode

3.2 RF Pins

The RF pins in RTL872xD are shown in Table 3-3.

Table 3-3 RF pins

Symbol	Type	QFN48	QFN68	QFN88	Description
RFGND	P	15	20	25	RF ground
RFIO_A	I/O	13	18	23	WL 5GHz RF signal
RXIN_A/GND	I	14	19	24	WL 5GHz RF input signal or RF ground
RFIN_G	I	16	21	26	WL/BT 2.4GHz RF input signal
RFOUT_G	O	17	22	27	WL/BT 2.4GHz RF output signal

3.3 Chip Enable Pin

The chip enable pin in RTL872xD is shown in Table 3-4.

Table 3-4 Chip enable pin

Symbol	Type	QFN48	QFN68	QFN88	Description
CHIP_EN	I	1	6	11	Enable chip <ul style="list-style-type: none"> ● 1: Enable chip ● 0: Shut down chip

3.4 Power Pins

The power pins in RTL872xD are shown in Table 3-5.

Table 3-5 Power pins

Symbol	Type	QFN48	QFN68	QFN88	Description
VA1833_XTAL	P	5	10	15	1.8V/3.3V power for Crystal Oscillator
VA11_AFE	P	4	9	14	1.1V power for WL/BT Analog Front End
VR1833_SYN	P	8	13	18	1.8V/3.3V power for RF Synthesizer
VR11_SYN	P	9	14	19	1.1V power for RF Synthesizer
VR1833_PA_A	P	12	17	22	1.8V/3.3V power for RF 5G Power amplifier
VR1833_PAD_A	P	11	16	21	1.8V/3.3V power for RF
VR11_RF2	P	10	15	20	1.1V power for RF 5G path
VR1833_PA_G	P	18	23	28	1.8V/3.3V power for RF 2.4G Power amplifier
VR11_RF1	P	19	24	29	1.1V power for RF 2.4G path
VD11_CORE	P	47, 25	62, 35	83, 46	1.1V power for digital core power
VD1833_SPS/VD1833_FLASH	P	40	55	70	1.8V/3.3V power for Flash I/O power and internal regulator input from 1.8V/3.3V to 1.1V
SW_LX	P	39	54	69	1.1V power output from Switching/Linear Regulator
GNDSPS	P	38	53	68	Ground for Switching/Linear Regulator
VA1833_USB	P	31	37	52	3.3V power for USB analog
VA1833_PLL	P	31	49	64	1.8V/3.3V power for PLL
VA11_PLL	P	35	50	65	1.1V power for PLL
VD18_PSRAM	P	36	51	66	1.8V power output from internal Linear regulator for PSRAM
VD1833_PMU	P	37	52	67	1.8V/3.3V power for Power Management Unit
AVCC_DRIV	P	-	66	88	1.8V/3.3V power supply for internal audio codec LDO.
AVCC	P	-	67	2	AVCC output from internal audio codec LDO, add a 1uF cap as close as possible.
AUDIO_VREF	P	-	1	3	Codec bandgap reference output, add a 4.7nF cap as close as possible.
MIC_BIAS	P	-	2	4	Microphone bias output
VD1833_GPIO	P	24, 48	5, 34	10, 45	1.8V/3.3V power for digital GPIO
AUDIO_GND	P	-	68	1	Audio ground

3.5 XTAL Pins

The XTAL pins in RTL872xD are shown in Table 3-6.

Table 3-6 XTAL pins

Symbol	Type	QFN48	QFN68	QFN88	Description
XI	I	7	12	17	Input of 40MHz Crystal Clock Reference
XO	O	6	11	16	Output of 40MHz Crystal Clock Reference

3.6 ADC and Cap-Touch Pins

The ADC and Cap-Touch pins in RTL872xD are shown in Table 3-7.

Table 3-7 ADC and Cap-Touch pins

Symbol	Type	QFN48		QFN68	QFN88	Description
		RTL8720DN RTL8720DM	RTL8720DF	RTL8721DM	RTL8722DM	
ADC_0/TOUCH_KEY0	I	-	-	44	59	ADC or Cap-Touch input pin, 3.3V tolerance
ADC_1/TOUCH_KEY1	I	-	-	45	60	ADC or Cap-Touch input pin, 3.3V tolerance
ADC_2/TOUCH_KEY2	I	-	-	46	61	ADC or Cap-Touch input pin, 3.3V tolerance
ADC_3/TOUCH_KEY3	I	-	-	47	62	ADC or Cap-Touch input pin, 3.3V tolerance
ADC_4	I	33	33	41	57	ADC input pin, 3.3V tolerance
ADC_5	I	32	-	42	56	ADC input pin, 3.3V tolerance
ADC_6	I	34	34	43	58	ADC input pin, 3.3V tolerance

VBAT_MEAS	I	-	32	48	63	ADC input pin, 5V tolerance
-----------	---	---	----	----	----	-----------------------------

3.7 USB Pins

The USB pins in RTL872xD are shown in Table 3-8.

Table 3-8 USB pins

Symbol	Type	QFN48	QFN68	QFN88	Description
HSDP	I/O	29	39	54	USB differential bus
HSDM	I/O	30	40	55	USB differential bus
RREF	I	28	38	53	External reference resistor for USB analog, 1% accuracy

3.8 Audio Codec Pins

The audio codec pins in RTL872xD are shown in Table 3-9.

Table 3-9 Audio codec pins

Symbol	Type	QFN48	QFN68	QFN88	Description
MIC1_P	AH	-	3	5	MIC1 input positive pad. Used as main MIC in dual MIC application. Programmable digital I/O, refer to pinmux table (UM0402 RTL872xD pinmux table).
MIC2_N	AH	-	-	7	MIC2 input negative pad. Used as 2 nd MIC in dual MIC application. Programmable digital I/O, refer to pinmux table.
MIC2_P	AH	-	4	6	MIC2 input positive pad. Used as 2 nd MIC in dual MIC application. Programmable digital I/O, refer to pinmux table.
AOUTN_R	AH	-	-	85	Right channel analog output negative pad. Programmable digital I/O, refer to pinmux table.
AOUTP_R	AH	-	64	84	Right channel analog output positive pad. Programmable digital I/O, refer to pinmux table.
AOUTN_L	AH	-	-	86	Left channel analog output negative pad. Programmable digital I/O, refer to pinmux table.
AOUTP_L	AH	-	65	87	Left channel analog output positive pad. Programmable digital I/O, refer to pinmux table.
AUXIN_R	AH	-	-	9	AUX input right channel pad. Programmable digital I/O, refer to pinmux table.
AUXIN_L	AH	-	-	8	AUX input left channel pad. Programmable digital I/O, refer to pinmux table.
AVCC_DRIV	PI	-	66	88	1.8V/3.3V power supply for internal audio codec LDO.
MIC_BIAS	PO	-	2	4	Microphone bias output
AUDIO_VREF	PO	-	1	3	Codec bandgap reference output, add a 4.7nF cap as close as possible.
AVCC	PO	-	67	2	AVCC output from internal audio codec LDO, add a 1uF cap as close as possible.
AUDIO_GND	PO	-	68	1	Audio ground

4 Memory Organization

4.1 Introduction

The RTL872xD incorporates several distinct memory regions. Program memory, data memory, registers and I/O ports are organized within the same linear 4Gbytes address space. The bytes are coded in memory in Little-Endian format.

The addressable memory space is divided into multiple main blocks, as shown in Table 4-1. All the memory areas that are not allocated to on-chip memories and peripherals are considered “RSVD” (reserved).

Table 4-1 Address space main blocks

Base Address	Top Address	Size	Function	Description	
0x0000_0000	0x0001_FFFF	128KB	KM0 ITCM ROM (actually 96KB)	32MB: KM0 Memory Address	
0x0002_0000	0x0002_7FFF	32KB	KM0 DTCM ROM (actually 16KB)		
0x0002_8000	0x0007_FFFF	352KB	RSVD		
0x0008_0000	0x0008_FFFF	64KB	KM0 SRAM		
0x0009_0000	0x000B_FFFF	192KB	RSVD		
0x000C_0000	0x000C_3FFF	16KB	Retention SRAM (actually 1KB) (the same port with KM0 SRAM)		
0x000C_4000	0x000F_FFFF	240KB	RSVD		
0x0010_0000	0x01FF_FFFF	31MB	RSVD		
0x0200_0000	0x07FF_FFFF	96MB	External PSRAM		224MB: External Memory Address
0x0800_0000	0x0FFF_FFFF	128MB	External Flash		
0x1000_0000	0x1007_FFFF	512KB	KM4 SRAM	256MB: KM4 Memory Address	
0x1008_0000	0x100D_FFFF	384KB	RSVD		
0x100E_0000	0x100F_FFFF	128KB	Extension SRAM (the same port with KM4 SRAM)		
0x1010_0000	0x101B_FFFF	768KB	KM4 ITCM ROM (actually 256KB)		
0x101C_0000	0x101D_7FFF	96KB	KM4 DTCM ROM		
0x101D_8000	0x101F_FFFF	160KB	RSVD		
0x1020_0000	0x1FFF_FFFF	254MB	RSVD		
0x2000_0000	0x3FFF_FFFF	512MB	RSVD		Reserved
0x4000_0000	0x47FF_FFFF	128MB	KM4 Peripherals		KM4 Peripherals Address
0x4800_0000	0x4FFF_FFFF	128MB	KM0 Peripherals		KM4 Peripherals Secure Address
0x5000_0000	0x57FF_FFFF	128MB	KM4 Peripherals Secure	KM0 Peripherals Address	
0x5800_0000	0xDFFF_FFFF	2176MB	RSVD	Reserved	
0xE000_0000	0xE0FF_FFFF	16MB	System PPB Device	RAM predefined	
0xE100_0000	0xFFFF_FFFF	496MB	RSVD	Reserved	

For the detailed mapping of available memory and register areas, refer to the following sections.

4.2 KM4 Memory

4.2.1 Memory Map and Register Boundary Addresses

Table 4-2 gives the boundary addresses of the peripherals available in the KM4 devices.

Table 4-2 KM4 register boundary addresses

Port Name	Security	Base Address	Top Address	Size
KM4_SRAM1	IDAU	0x1000_0000	0x1003_FFFF	256KB
KM4_SRAM2	IDAU	0x1004_0000	0x1007_FFFF	256KB
Extension SRAM	IDAU	0x100E_0000	0x100F_FFFF	128KB
PSRAM Memory	IDAU	0x0200_0000	0x07FF_FFFF	96MB

HS_SYSON	Non-Secure	0x4000_0000	0x4000_0FFF	4KB
	Secure	0x5000_0000	0x5000_0FFF	4KB
HS_TIM0 ~ 3/4/5	Non-Secure	0x4000_2000	0x4000_2FFF	4KB
HS_UART0	Non-Secure	0x4000_4000	0x4000_4FFF	4KB
HS_IPC	Non-Secure	0x4000_6000	0x4000_6FFF	4KB
HS_USI	Non-Secure	0x4000_8000	0x4000_83FF	1KB
HS_UART1 (Bluetooth)	Non-Secure	0x4000_A000	0x4000_AFFF	4KB
RXI300_KM4	Non-Secure	0x4000_C000	0x4000_CFFF	4KB
	Secure	0x5000_C000	0x5000_CFFF	4KB
HS_SPI1	Non-Secure	0x4000_E000	0x4000_E7FF	2KB
Audio Codec	Non-Secure	0x4001_0000	0x4001_0FFF	4KB
HS_IR	Non-Secure	0x4001_2000	0x4001_2FFF	4KB
PSRAM Controller	Non-Secure	0x4001_4000	0x4001_4FFF	4KB
I ² S	Non-Secure	0x4002_0000	0x4002_03FF	1KB
Secure Engine	Non-Secure	0x4002_2000	0x4002_5FFF	16KB
	Secure	0x5002_2000	0x5002_5FFF	16KB
SDIO Host	Non-Secure	0x4002_6000	0x4002_9FFF	16KB
HS_GDMA0	Non-Secure	0x4002_A000	0x4002_BFFF	8KB
	Secure	0x5002_A000	0x5002_BFFF	8KB
SDIO Device	Non-Secure	0x4002_C000	0x4002_FFFF	16KB
USB	Non-Secure	0x4004_0000	0x4006_FFFF	192KB
LCD Controller	Non-Secure	0x4007_0000	0x4007_4FFF	20KB
HS_SPI0	Non-Secure	0x4007_8000	0x4007_87FF	2KB
Wi-Fi	Non-Secure	0x4008_0000	0x400A_FFFF	192KB
KM0 BRG	Non-Secure	0x0008_0000	0x0008_FFFF	64KB
		0x000C_0000	0x000C_3FFF	16KB
		0x4800_0000	0x4803_FFFF	256KB
Flash Controller	Non-Secure	0x4808_0000	0x4808_0FFF	4KB
Flash Memory	IDAU	0x0800_0000	0x0FFF_FFFF	128MB

4.2.2 Embedded SRAM

The KM4 contains up to a total 512KB of contiguous, on-chip static RAM memory. This embedded SRAM can be accessed as bytes (8 bits), half-words (16 bits) or full words (32 bits). It is divided into the following two blocks which can be accessed by both KM4 and KM0.

- KM4 SRAM1 (up to 256KB)
- KM4 SRAM2 (up to 256KB)

Dividing SRAM into two slave ports allows user's program to potentially obtain better performance. For example, simultaneous access to SRAM1 by the CPU and by the system DMA controller does not result in any bus stalls for either master.

Generally speaking, the CPU reads or writes all peripheral data at some point, even when all such data is read from or sent to a peripheral by DMA. So, minimizing stalls is likely to involve putting data to/from different peripherals in RAM on each port.

Alternatively, sequences of data from the same peripheral can be alternated between RAM on each port. This could be helpful if DMA fills or empties a RAM buffer, and signals the CPU before proceeding on to a second buffer. The CPU then tends to access the data while the DMA is using the other RAM.

In power domains, the entire SRAM is also divided into three blocks:

- SRAM_PD1 (up to 256KB)
- SRAM_PD2 (up to 128KB)
- SRAM_PD3 (up to 128KB)

Each block can be disabled or enabled individually in the Power Management Unit (PMU) block to save power, and the entire SRAM can also keep power for quickly resuming from sleep mode when system enters sleep mode.

4.2.3 Extension SRAM

When Bluetooth is disabled, more 64KB SRAM will be extended. This SRAM can also be accessed by both KM4 and KM0, up to 50MHz*32 bits.

4.3 KM0 Memory

4.3.1 Memory Map and Register Boundary Addresses

Table 4-3 gives the boundary addresses of the peripherals available in the KM0 devices.

Table 4-3 KM0 register boundary addresses

Port Name	Base Address	Top Address	Size
KM0_SRAM	0x0008_0000	0x0008_FFFF	64KB
1KB Retention SRAM	0x000C_0000	0x000C_3FFF	16KB
KM4 BRG	0x1000_0000	0x1007_FFFF	512KB
	0x4000_0000	0x4007_FFFF	512KB
Wi-Fi FW	0x4008_0000	0x400A_FFFF	192KB
LP_SYSON	0x4800_0000	0x4800_0FFF	4KB
LP_TIM0 ~ 3/4/5	0x4800_2000	0x4800_2FFF	4KB
LP_RTC	0x4800_4000	0x4800_43FF	1KB
LP_IPC	0x4800_6000	0x4800_63FF	1KB
Key-Scan	0x4800_A000	0x4800_A3FF	1KB
I ² C0	0x4800_C000	0x4800_C3FF	1KB
UART3	0x4800_E000	0x4800_E3FF	1KB
LP_GDMA0	0x4801_0000	0x4801_07FF	2KB
UART2 (LOGUART)	0x4801_2000	0x4801_23FF	1KB
GPIOA/B	0x4801_4000	0x4801_47FF	2KB
RX1300_KM0	0x4801_8000	0x4801_8FFF	4KB
SGPIO	0x4801_A000	0x4801_AFFF	4KB
Cap-Touch	0x4801_C000	0x4801_C7FF	2KB
ADC	0x4801_C800	0x4801_CBFF	1KB
Comparator	0x4801_CC00	0x4801_CFFF	1KB
Q-Decoder	0x4801_E000	0x4801_EFFF	4KB
Flash Controller	0x4808_0000	0x4808_0FFF	4KB
Flash Memory	0x0800_0000	0x0FFF_FFFF	128MB

4.3.2 Embedded SRAM

The KM0 features 64KB of system SRAM, the embedded SRAM can be accessed as bytes (8 bits), half-words (16 bits) or full words (32 bits).

This SRAM can be accessed by both KM4 and KM0.

4.4 Retention SRAM

The RTL872xD features 1KB of retention SRAM in order to allow saving data with minimal power usage during deepsleep mode.

This SRAM can be accessed by both KM4 and KM0.

4.5 SPI Flash Memory

The SPI Flash Controller manages CPU I-Code and D-Code accesses to the Flash memory. It implements the erase and program Flash memory operations, and the read/write protection mechanisms. It accelerates code execution with a system of instruction prefetch and cache lines.

4.6 PSRAM

4MB 8IO DDR PSRAM is included in RTL872xD, up to 50MHz DDR.

Realtek Confidential for 747632169@qq.com

5 Nested Vectored Interrupt Controller (NVIC)

5.1 Features

All interrupts including the core exceptions are managed by the NVIC. The nested vector interrupt controller NVIC includes the following features:

- Nested Vectored Interrupt Controller that is an integral part of each CPU.
- Tightly coupled interrupt controller provides low interrupt latency.
- Controls system exceptions and peripheral interrupts.
- The NVIC of the KM4 supports:
 - 58 vectored interrupts.
 - 8 programmable interrupt priority levels with hardware priority level masking.
 - Vector table offset register VTOR.
- The NVIC of the KM0 supports:
 - 32 vectored interrupts.
 - 4 programmable interrupt priority levels with hardware priority level masking.
 - Vector table offset register VTOR.
- Support for NMI from any interrupt.

The NVIC and the processor core interface are closely coupled, which enables low latency interrupt processing and efficient processing of late arriving interrupts.

5.2 NVIC Diagram

The diagram of NVIC is shown in Figure 5-1.

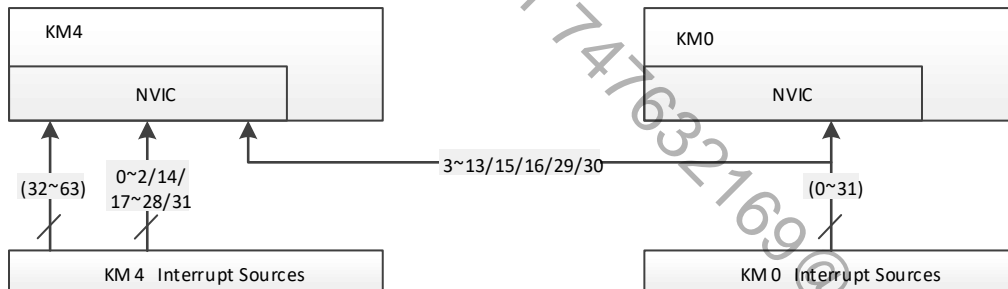

Figure 5-1 NVIC diagram

Most of KM0 interrupt signals are linked to KM4 NVIC at the same interrupt number like LOGUART, and other KM0 interrupt signals are not linked to KM4 NVIC like WDG/RXI300/IPC.

This mechanism let KM4 use KM0's peripheral like it is KM4's peripheral. But if an interrupt signal is shared by KM0 and KM4, just only one CPU can open this interrupt, if not, software will hang.

5.3 NVIC Table

Table 5-1 lists the interrupt sources for each peripheral function. Each peripheral device may have one or more interrupt lines to the Vectored Interrupt Controller. Each line may represent more than one interrupt source. The interrupt number does not imply any interrupt priority.

NOTE

The macro "configLIBRARY_MAX_SYSCALL_INTERRUPT_PRIORITY", which is used to define the highest interrupt priority controlled by FreeRTOS, is very important to interrupt. If the interrupt safe FreeRTOS API functions are called by the interrupt service routine, the priority of it must not be higher than this macro. Do not call RTOS_ISR functions from any interrupt that has a higher priority than this macro.

Table 5-1 NVIC table

IRQ	KM4 Name	KM0 Name	Description
	Reset	Reset	Reset
	NMI	NMI	Non-maskable interrupts (external NMI input). The WDG is linked to the NMI vector
	Hard Fault	Hard Fault	All fault conditions if the corresponding fault handler is not enabled
	MemManager Fault	MemManager Fault	Memory management fault; Memory Protection Unit (MPU) violation or access to illegal locations
	Bus Fault	Bus Fault	Bus error; occurs when Advanced High-Performance Bus (AHB) interface receives an error response from a bus slave (also called pre-fetch abort if it is an instruction fetch or data abort if it is a data access)
	Usage Fault	Usage Fault	Exceptions resulting from program error or trying to access coprocessor (the Cortex-M4 does not support a coprocessor)
	RSVD	RSVD	Reserved
	SVC	SVC	Supervisor Call
	Debug Monitor	Debug Monitor	Debug monitor (breakpoints, watch-points, or external debug requests)
	RSVD	RSVD	Reserved
	PendSV	PendSV	Pendable Service Call
	SYSTICK	SYSTICK	System Tick Timer
0	KM4_System_ISR	KM0_System_ISR	<ul style="list-style-type: none"> ● KM4: System ISR include wakeup event, like HS BT-/USB-dev/SDIO-dev/UART0 ● KM0: LS peripheral wakeup event, like GPIO/LUART/I2C0, etc.
1	WDG_ISR_H	WDG_ISR_L	KM4 & KM0 watchdog warning interrupt
2	RXI300_IRQ_H	RXI300_IRQ_L	KM4 & KM0 RXI300 platform interrupt
3	UART log	UART log	KM4 & KM0 LP_UART0 (LOGUART) interrupt
4	GPIOA	GPIOA	KM4 & KM0 GPIO PortA Interrupt (GPIO IPO PORTA)
5	RTC	RTC	KM4 & KM0 RTC interrupt
6	I2C0	I2C0	KM4 & KM0 I2C0 interrupt
7	SPI_FLASH	SPI_FLASH	KM4 & KM0 SPI FLASH interrupt
8	GPIOB	GPIOB	KM4 & KM0 GPIO PortB Interrupt (GPIO IP1 PORTA)
9	LUART	LUART	KM4 & KM0 LP_UART1 interrupt
10	Key-Scan	Key-Scan	KM4 & KM0 Key-Scan interrupt
11	Cap-Touch	Cap-Touch	KM4 & KM0 Cap-Touch interrupt
12	BOR2	BOR2	KM4 & KM0 BOR Interrupt
13	SGPIO	SGPIO	KM4 & KM0 SGPIO interrupt
14	IPC_KM0	IPC_KM4	IPC interrupt: <ul style="list-style-type: none"> ● KM0 IPC interrupt KM4 ● KM4 IPC interrupt KM0
15	ADC	ADC	KM4 & KM0 ADC interrupt
16	Q-Decoder	Q-Decoder	KM4 & KM0 Q-Decoder interrupt
17	HTimer0	LTimer0	<ul style="list-style-type: none"> ● KM4 HTimer0 interrupt ● KM0 LTimer0 interrupt
18	HTimer1	LTimer1	<ul style="list-style-type: none"> ● KM4 HTimer1 interrupt ● KM0 LTimer1 interrupt
19	HTimer2	LTimer2	<ul style="list-style-type: none"> ● KM4 HTimer2 interrupt ● KM0 LTimer2 interrupt
20	HTimer3	LTimer3	<ul style="list-style-type: none"> ● KM4 HTimer3 interrupt ● KM0 LTimer3 interrupt
21	HTimer4	LTimer4	<ul style="list-style-type: none"> ● KM4 HTimer4 interrupt ● KM0 LTimer4 interrupt
22	HTimer5	LTimer5	<ul style="list-style-type: none"> ● KM4 HTimer5 interrupt ● KM0 LTimer5 interrupt
23	LCDC	LGDMA0_Channel0	<ul style="list-style-type: none"> ● KM4 LCDC interrupt ● KM0 LGDMA0_Channel0 interrupt
24	USB	LGDMA0_Channel1	<ul style="list-style-type: none"> ● KM4 USB interrupt ● KM0 LGDMA0_Channel1 interrupt

25	SDIO_DEV	LGDMA0_Channel2	<ul style="list-style-type: none"> ● KM4 SDIO_DEV interrupt ● KM0 LGDMA0_Channel2 interrupt
26	SD_HOST	Wi-Fi FISR (0x134) + FESR (0x124)	<ul style="list-style-type: none"> ● KM4 SD_HOST interrupt ● KM0 Wi-Fi FISR + FESR interrupt
27	IPSEC	Wi-Fi FTSR (0x13C) + mailbox	<ul style="list-style-type: none"> ● KM4 SD_HOST interrupt ● KM0 Wi-Fi FTSR + mailbox interrupt
28	I2S0	LGDMA0_Channel3	<ul style="list-style-type: none"> ● KM4 I2S0 interrupt ● KM0 LGDMA0_Channel3 interrupt
29	PWR_DOWN	PWR_DOWN	KM4 & KM0 PWR_DOWN interrupt, this interrupt will be triggered when power down pin push under power down interrupt mode
30	ADC_COMP	ADC_COMP	KM4 & KM0 ADC comparator interrupt
31	WL_DMA	KM4_WAKE_ISR	<ul style="list-style-type: none"> ● KM4 WL_DMA interrupt ● KM0: KM4 peripherals wake interrupt, the same as KM4_System_ISR
32	WL_PROTOCOL (0xB4)	-	KM4 WL_PROTOCOL interrupt
33	PSRAMC	-	KM4 PSRAMC interrupt
34	UART0	-	KM4 HS_UART0 interrupt
35	UART1_BT	-	KM4 HS_UART1_BT interrupt
36	SPI0	-	KM4 HS_SPI0 interrupt
37	SPI1	-	KM4 HS_SPI1 interrupt
38	HUSIO	-	KM4 HS_USIO interrupt
39	IR	-	KM4 IR interrupt
40	BT_SCORE_BOARD	-	KM4 BT_SCORE_BOARD interrupt
41	GDMA0_Channel0	-	KM4 HS_GDMA0_Channel0 interrupt
42	GDMA0_Channel1	-	KM4 HS_GDMA0_Channel1 interrupt
43	GDMA0_Channel2	-	KM4 HS_GDMA0_Channel2 interrupt
44	GDMA0_Channel3	-	KM4 HS_GDMA0_Channel3 interrupt
45	GDMA0_Channel4	-	KM4 HS_GDMA0_Channel4 interrupt
46	GDMA0_Channel5	-	KM4 HS_GDMA0_Channel5 interrupt
47	RSVD	-	Reserved
48	RSVD	-	Reserved
49	RSVD	-	Reserved
50	IPSEC_S	-	KM4 HS_IPSEC TrustZone interrupt
51	RXI300_IRQ_S	-	KM4 HS_RXI300 TrustZone interrupt
52	GDMA0_Channel0_S	-	KM4 HS_GDMA0_Channel0 TrustZone interrupt
53	GDMA0_Channel1_S	-	KM4 HS_GDMA0_Channel1 TrustZone interrupt
54	GDMA0_Channel2_S	-	KM4 HS_GDMA0_Channel2 TrustZone interrupt
55	GDMA0_Channel3_S	-	KM4 HS_GDMA0_Channel3 TrustZone interrupt
56	GDMA0_Channel4_S	-	KM4 HS_GDMA0_Channel4 TrustZone interrupt
57	GDMA0_Channel5_S	-	KM4 HS_GDMA0_Channel5 TrustZone interrupt

6 Radio Characteristics

6.1 RF Block Diagram

The radio frequency (RF) block diagram of RTL872xD, including Wi-Fi and BLE modem, is given in Figure 6-1.

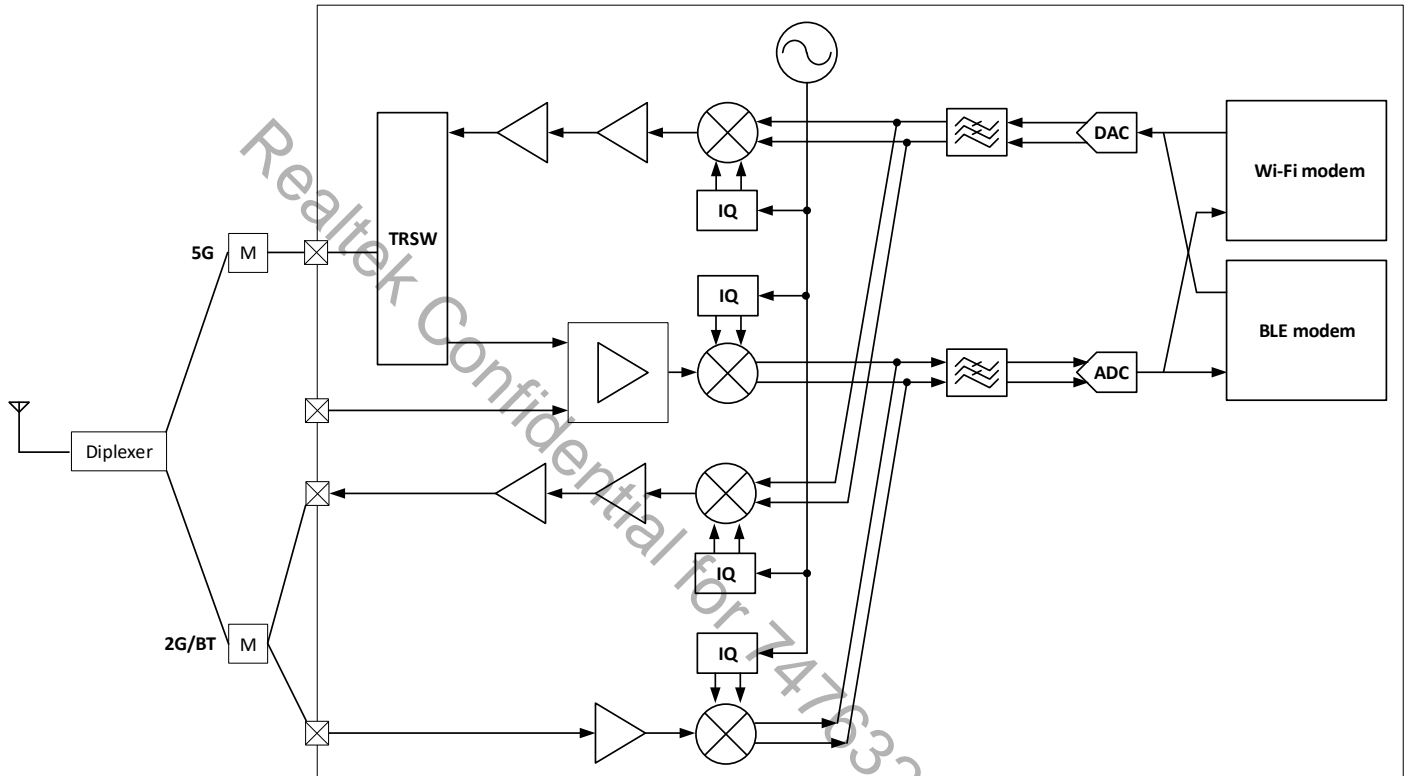

Figure 6-1 RF block diagram

6.2 Wi-Fi Radio Characteristics

The RF specifications of Wi-Fi are described in the tables below. These values are measured on the QFN68 board.

6.2.1 Wi-Fi 2.4GHz Band RF Receiver Specifications

Parameter	Description	Performance (1.8V)			Performance (3.3V)			Unit
		Min.	Typ.	Max.	Min.	Typ.	Max.	
Frequency Range	Center channel frequency	2412	-	2484	2412	-	2484	MHz
Rx Sensitivity	1Mbps CCK	-	-98	-	-	-98	-	dBm
	2Mbps CCK	-	-96	-	-	-96	-	
	5.5Mbps CCK	-	-94	-	-	-94	-	
	11Mbps CCK	-	-91	-	-	-91	-	
Rx Sensitivity	BPSK rate 1/2, 6Mbps OFDM	-	-96	-	-	-95	-	dBm
	BPSK rate 3/4, 9Mbps OFDM	-	-94	-	-	-94	-	
	QPSK rate 1/2, 12Mbps OFDM	-	-93	-	-	-93	-	
	QPSK rate 3/4, 18Mbps OFDM	-	-90	-	-	-90	-	

	16QAM rate 1/2, 24Mbps OFDM	-	-87	-	-	-87	-	
	16QAM rate 3/4, 36Mbps OFDM	-	-84	-	-	-84	-	
	64QAM rate 1/2, 48Mbps OFDM	-	-79	-	-	-79	-	
	64QAM rate 3/4, 54Mbps OFDM	-	-77	-	-	-77	-	
Rx Sensitivity BW = 20MHz Mixed Mode 800ns Guard Interval Non-STBC	MCS 0, BPSK rate 1/2	-	-95	-	-	-95	-	dBm
	MCS 1, QPSK rate 1/2	-	-92	-	-	-92	-	
	MCS 2, QPSK rate 3/4	-	-89	-	-	-89	-	
	MCS 3, 16QAM rate 1/2	-	-86	-	-	-86	-	
	MCS 4, 16QAM rate 3/4	-	-83	-	-	-83	-	
	MCS 5, 64QAM rate 2/3	-	-78	-	-	-78	-	
	MCS 6, 64QAM rate 3/4	-	-77	-	-	-77	-	
	MCS 7, 64QAM rate 5/6	-	-75	-	-	-75	-	
Rx Sensitivity BW = 40MHz Mixed Mode 800ns Guard Interval Non-STBC	MCS 0, BPSK rate 1/2	-	-93	-	-	-93	-	dBm
	MCS 1, QPSK rate 1/2	-	-89	-	-	-89	-	
	MCS 2, QPSK rate 3/4	-	-86	-	-	-86	-	
	MCS 3, 16QAM rate 1/2	-	-83	-	-	-83	-	
	MCS 4, 16QAM rate 3/4	-	-80	-	-	-80	-	
	MCS 5, 64QAM rate 2/3	-	-75	-	-	-75	-	
	MCS 6, 64QAM rate 3/4	-	-74	-	-	-74	-	
	MCS 7, 64QAM rate 5/6	-	-72	-	-	-72	-	
Maximum Receive Level	6Mbps OFDM	-	0	-	-	0	-	dBm
	54Mbps OFDM	-	0	-	-	0	-	
	MCS 0	-	0	-	-	0	-	
	MCS 7	-	0	-	-	0	-	
Receive Adjacent Channel Rejection	1Mbps CCK	-	43	-	-	43	-	dBm
	11Mbps CCK	-	40	-	-	41	-	
	BPSK rate 1/2, 6Mbps OFDM	-	40	-	-	40	-	
	64QAM rate 3/4, 54Mbps OFDM	-	22	-	-	22	-	
	HT20, MCS 0, BPSK rate 1/2	-	39	-	-	39	-	
	HT20, MCS 7, 64QAM rate 5/6	-	20	-	-	20	-	
	HT40, MCS 0, BPSK rate 1/2	-	30	-	-	29	-	
	HT40, MCS 7, 64QAM rate 5/6	-	11	-	-	10	-	

6.2.2 Wi-Fi 2.4GHz Band RF Transmitter Specifications

Parameter	Description	Performance (1.8V)			Performance (3.3V)			Unit
		Min.	Typ.	Max.	Min.	Typ.	Max.	
Frequency Range	Center channel frequency	2412	-	2484	2412	-	2484	MHz
Output power with spectral mask and EVM compliance ¹	1Mbps CCK	-	14	15	-	20	21	dBm
	11Mbps CCK	-	12	15	-	18	21	
	BPSK rate 1/2, 6Mbps OFDM	-	14	15	-	20	21	
	64QAM rate 3/4, 54Mbps OFDM	-	11	12	-	17	18	
	HT20-MCS 0, BPSK rate 1/2	-	13	14	-	19	20	
	HT20-MCS 7, 64QAM rate 5/6	-	10	11	-	16	17	
	HT40-MCS 0, BPSK rate 1/2	-	13	14	-	19	20	
HT40-MCS 7, 64QAM rate 5/6	-	10	11	-	16	17		
Tx EVM	BPSK rate 1/2, 6Mbps OFDM	-	-	-5	-	-	-5	dB
	64QAM rate 3/4, 54Mbps OFDM	-	-	-25	-	-	-25	
	HT20-MCS 0, BPSK rate 1/2	-	-	-5	-	-	-5	
	HT20-MCS 7, 64QAM rate 5/6	-	-	-28	-	-	-28	
	HT40-MCS 0, BPSK rate 1/2	-	-	-5	-	-	-5	
HT40-MCS 7, 64QAM rate 5/6	-	-	-28	-	-	-28		
Output power variation ²	After do power trim at FT	-1.5	-	1.5	-1.5	-	1.5	dBm
Carrier suppression		-	-	-30	-	-	-30	dBm

Harmonic output power (IC port)	2nd harmonic	-	-36	-34	-	-23	-21.9	dBm
	3rd harmonic	-	-26	-24	-	-15	-14	

- Power level is tested after DPK on.
- VDD18 voltage is within $\pm 5\%$ of typical value.

6.2.3 Wi-Fi 5GHz Band RF Receiver Specifications

Parameter	Description	Performance (1.8V)			Performance (3.3V)			Unit
		Min.	Typ.	Max.	Min.	Typ.	Max.	
Frequency Range	Center channel frequency	5180	-	5825	5180	-	5825	MHz
Rx Sensitivity	BPSK rate 1/2, 6Mbps OFDM	-	-94	-	-	-93	-	dBm
	BPSK rate 3/4, 9Mbps OFDM	-	-93	-	-	-93	-	
	QPSK rate 1/2, 12Mbps OFDM	-	-92	-	-	-92	-	
	QPSK rate 3/4, 18Mbps OFDM	-	-89	-	-	-89	-	
	16QAM rate 1/2, 24Mbps OFDM	-	-86	-	-	-86	-	
	16QAM rate 3/4, 36Mbps OFDM	-	-83	-	-	-83	-	
	64QAM rate 1/2, 48Mbps OFDM	-	-78	-	-	-78	-	
	64QAM rate 3/4, 54Mbps OFDM	-	-76	-	-	-76	-	
Rx Sensitivity BW = 20MHz HT Mixed Mode 800ns Guard Interval Non-STBC	MCS 0, BPSK rate 1/2	-	-94	-	-	-93	-	dBm
	MCS 1, QPSK rate 1/2	-	-91	-	-	-91	-	
	MCS 2, QPSK rate 3/4	-	-88	-	-	-88	-	
	MCS 3, 16QAM rate 1/2	-	-85	-	-	-85	-	
	MCS 4, 16QAM rate 3/4	-	-82	-	-	-82	-	
	MCS 5, 64QAM rate 2/3	-	-77	-	-	-77	-	
	MCS 6, 64QAM rate 3/4	-	-76	-	-	-75	-	
	MCS 7, 64QAM rate 5/6	-	-74	-	-	-74	-	
Rx Sensitivity BW = 40MHz HT Mixed Mode 800ns Guard Interval Non-STBC	MCS 0, BPSK rate 1/2	-	-91	-	-	-91	-	dBm
	MCS 1, QPSK rate 1/2	-	-88	-	-	-88	-	
	MCS 2, QPSK rate 3/4	-	-85	-	-	-85	-	
	MCS 3, 16QAM rate 1/2	-	-82	-	-	-82	-	
	MCS 4, 16QAM rate 3/4	-	-79	-	-	-79	-	
	MCS 5, 64QAM rate 2/3	-	-74	-	-	-74	-	
	MCS 6, 64QAM rate 3/4	-	-73	-	-	-73	-	
	MCS 7, 64QAM rate 5/6	-	-71	-	-	-71	-	
Maximum Receive Level	6Mbps OFDM	-	0	-	0	-	-	dBm
	54Mbps OFDM	-	0	-	0	-	-	
	MCS 0	-	0	-	0	-	-	
	MCS 7	-	0	-	0	-	-	
Receive Adjacent Channel Rejection	BPSK rate 1/2, 6Mbps OFDM	-	21	-	-	21	-	dBm
	64QAM rate 3/4, 54Mbps OFDM	-	12	-	-	11	-	
	HT20, MCS 0, BPSK rate 1/2	-	21	-	-	19	-	
	HT20, MCS 7, 64QAM rate 5/6	-	7	-	-	7	-	
	HT40, MCS 0, BPSK rate 1/2	-	30	-	-	30	-	
	HT40, MCS 7, 64QAM rate 5/6	-	12	-	-	13	-	

6.2.4 Wi-Fi 5GHz Band RF Transmitter Specifications

Parameter	Description	Performance (1.8V)			Performance (3.3V)			Unit
		Min.	Typ.	Max.	Min.	Typ.	Max.	
Frequency Range	Center channel frequency	5180	-	5825	5180	-	5825	MHz
Output power with spectral mask and EVM compliance ¹	BPSK rate 1/2, 6Mbps OFDM	-	12	13	-	18	19	dBm
	64QAM rate 3/4, 54Mbps OFDM	-	9	10	-	14	15	
	HT20-MCS 0, BPSK rate 1/2	-	11	12	-	17	18	

	HT20-MCS 7, 64QAM rate 5/6	-	8	9	-	13	14	
	HT40-MCS 0, BPSK rate 1/2	-	11	12	-	17	18	
	HT40-MCS 7, 64QAM rate 5/6	-	8	9	-	13	14	
Tx EVM	BPSK rate 1/2, 6Mbps OFDM	-	-	-5	-	-	-5	dB
	64QAM rate 3/4, 54Mbps OFDM	-	-	-25	-	-	-25	
	HT20-MCS 0, BPSK rate 1/2	-	-	-5	-	-	-5	
	HT20-MCS 7, 64QAM rate 5/6	-	-	-28	-	-	-28	
	HT40-MCS 0, BPSK rate 1/2	-	-	-5	-	-	-5	
	HT40-MCS 7, 64QAM rate 5/6	-	-	-28	-	-	-28	
Output power variation ²	After doing power trim at FT	-1.5	-	1.5	-1.5	-	1.5	dBm
Carrier suppression		-	-	-30	-	-	-30	dBm

1. Power level is tested after DPK on.
2. VDD18 voltage is within $\pm 5\%$ of typical value.

6.3 BT Radio Characteristics

The RF specifications of BT are described in the tables below. Both the transmitter specifications and the receiver specifications basically follow the Bluetooth SIG specifications.

6.3.1 BT RF Transmitter Specifications

Parameter	Condition	Min.	Typ.	Max.	Unit
Frequency Range		2402		2480	MHz
Tx Output Power	LE1M	-10	4.5		dBm
	LE2M				
Modulation Characteristics (LE1M)	$\Delta F1$ Avg.	225		275	kHz
	$\Delta F2$ Max.	185			
	Modulation Index ($\Delta F2$ Avg./ $\Delta F1$ Avg.)	0.8			
Modulation Characteristics (LE2M)	$\Delta F1$ Avg.	450		550	kHz
	$\Delta F2$ Max.	370			
	Modulation Index ($\Delta F2$ Avg./ $\Delta F1$ Avg.)	0.8			
Modulation Characteristics Stable Modulation (LE1M)	$\Delta F1$ Avg.	247.5		252.5	kHz
	$\Delta F2$ Max.	185			
	Modulation Index ($\Delta F2$ Avg./ $\Delta F1$ Avg.)	0.8			
Modulation Characteristics Stable Modulation (LE2M)	$\Delta F1$ Avg.	495		505	kHz
	$\Delta F2$ Max.	370			
	Modulation Index ($\Delta F2$ Avg./ $\Delta F1$ Avg.)	0.8			

6.3.2 BT RF Receiver Specifications

Parameter	Condition	Min.	Typ.	Max.	Unit
Frequency Range		2402	-	2480	MHz
Rx Sensitivity	LE1M	-100.9	-	-	dBm
	LE2M	-96.8	-	-	

7 Electrical Characteristics

7.1 Temperature Limit Ratings

The temperature limit ratings are the parameter values or ranges which can cause permanent damage if exceeded.

Table 7-1 Temperature limit ratings

Parameter	Part Number	Minimum	Maximum	Unit
Storage Temperature	QFN48/QFN68/QFN88	-55	+125	°C
Ambient Operating Temperature (T _a)	QFN48/QFN68/QFN88	-20	+85	°C
	QFN48 wide-range temperature	-40	+105	
Junction Temperature (T _j)	QFN48/QFN68/QFN88	-40	+125	°C

7.2 ESD Characteristics

The Electro-Static discharge (ESD) characteristics of RTL872xD are listed in Table 7-2.

Table 7-2 ESD characteristics

Reliability test	Standards	Test condition	Result
Human Body Model (HBM)	JEDEC EIA/JESD22-A114	±2000V	Pass
Charge Device Model (CDM)	JEDEC EIA/JESD22-C101	±500V	Pass

7.3 DC Characteristics

The direct current (DC) characteristics of power supply and digital I/O pin are illustrated in the following sections.

7.3.1 Power Supply

The power supply DC characteristics of RTL872xD are shown in Table 7-3.

Table 7-3 Power supply DC characteristics

Symbol	Parameter	Minimum	Typical	Maximum	Unit
VA1833_XTAL, VR1833_SYN, VR1833_PAD_A, VR1833_PA_A, VR1833_PA_G, VA1833_USB, VA1833_PLL, VD1833_PMU, VD1833_SPS/VD1833_FLASH, AVCC_DRIV	3.3V Supply Voltage	3.0	3.3	3.6	V
	1.85V Supply Voltage	1.76	1.85	2.035	V
VD1833_GPIO	Digital I/O Supply Voltage	1.76	1.8 ~ 3.3	3.6	V
VA11_AFE, VA11_SYN, VA11_RF1, VA11_RF2, VD11_CORE, VA11_PLL	1.1V Core Supply Voltage	1.05	1.1	1.21	V
IDD33 ¹	3.3V Rating Current (with internal regulator and integrated CMOS PA)	-	-	450	mA
IDD18 ¹	1.85V Rating Current (with internal regulator and integrated CMOS PA)			800	mA
IDD_IO	I/O Rating Current (including VDD_IO)	-	-	200	mA
IDD_IO_1833	1.85V or 3.3V I/O Rating Current	-	-	50	mA

1. IDD33 is for 3.3V supply voltage, and IDD18 is for 1.85V supply voltage, to supply pins "VA1833_XTAL, VR1833_SYN, VR1833_PAD_A, VR1833_PA_A, VR1833_PA_G, VA1833_USB, VA1833_PLL, VD1833_PMU, VD1833_SPS/VD1833_FLASH, AVCC_DRIV".

There are some restrictions both for the application of 1.85V supply voltage and 3.3V supply voltage.

- On 1.85V supply voltage module, make sure to use wide-range voltage Flash; otherwise, the Flash cannot be accessed.

- On 3.3V supply voltage module, make sure your circuit satisfy the following two points; otherwise, you should refer to HDK to add a Reset IC.
 - The power-on voltage waveform is consistent with Figure 7-1.
 - The power-off voltage can drop to under 0.3V finally.

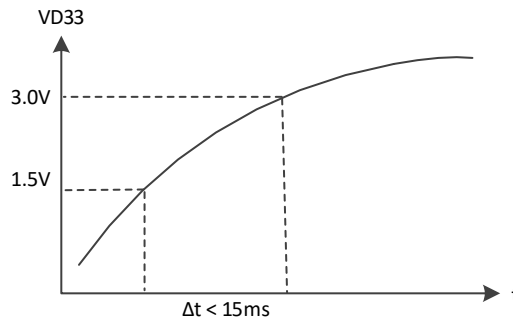

Figure 7-1 Power-on waveform

7.3.2 Digital I/O Pin

The digital I/O pin DC characteristics of RTL872xD are shown in Table 7-4 and Table 7-5, which illustrate 3.3V and 1.8V respectively.

Table 7-4 Digital I/O pin DC characteristics (3.3V)

Symbol	Parameter	Conditions	Minimum	Typical	Maximum	Unit
V _{IH}	Input-High Voltage	LVTTL	2.0	-	-	V
V _{IL}	Input-Low Voltage	LVTTL	-	-	0.8	V
V _{OH}	Output-High Voltage	LVTTL	2.4	-	-	V
V _{OL}	Output-Low Voltage	LVTTL	-	-	0.4	V
I _{T+}	Schmitt-trigger High Level		1.78	1.87	1.97	V
I _{T-}	Schmitt-trigger Low Level		1.36	1.45	1.56	V
I _{IL}	Input-Leakage Current	V _{IN} = 3.3V or 0	-10	±1	10	μA

Table 7-5 Digital I/O pin DC characteristics (1.8V)

Symbol	Parameter	Conditions	Minimum	Typical	Maximum	Unit
V _{IH}	Input-High Voltage	CMOS	0.65 * V _{CC}	-	-	V
V _{IL}	Input-Low Voltage	CMOS	-	-	0.35 * V _{CC}	V
V _{OH}	Output-High Voltage	CMOS	V _{CC} -0.45	-	-	V
V _{OL}	Output-Low Voltage	CMOS	-	-	0.45	V
I _{T+}	Schmitt-trigger High Level	-	1.02	1.09	1.14	V
I _{T-}	Schmitt-trigger Low Level	-	0.67	0.73	0.87	V
I _{IL}	Input-Leakage Current	V _{IN} = 1.8V or 0	-10	±1	10	μA

7.4 ADC Characteristics

The ADC characteristics of RTL872xD are shown in Table 7-6.

Table 7-6 SAR ADC characteristics

Parameter	Conditions	Min.	Typ.	Max.	Unit
Temperature		-40	25	125	°C
Resolution	Bypass mode		12		Bits
	Resistor divider mode (1/3.3)		12		Bits
Clock Source	From digital			1000	kHz
DC Offset Error	Cover V _{BAT} =1.62~3.63V		2		LSB

	Temperature=-40~125°C				
Gain Error	Cover VBAT=1.62~3.63V Temperature=-40~125°C		2		LSB
DNL			-1		LSB
INL			±3		LSB
Input Voltage Range	External channel (ch0 ~ ch7)	0		3.63	V
	External channel 0 (VBAT)	0		5	V
Input Impedance	Bypass mode		4		MΩ
	Resistor divider mode (1/3.3)		500		kΩ
Sampling Capacitance	Bypass mode		1.9		pF
	Resistor divider mode (1/3.3)		1.9		pF
Conversion Time			1		us
Sampling Rate ¹				1	MHz
Power Consumption	1 Msample/s		190		uA

1. Sampling rate depends on the output impedance of sensor and resistor divider, $8.4 * R_{OUT} * 1.9 \text{ pF} - 0.5 \text{ us} < 1/f_s$.

7.5 XTAL Oscillator

The RTL872xD has a built-in 40MHz crystal oscillation circuit to provide a stable, controllable system clock. With the built-in capacitor, the clock offset can be fine-tuned in the mass production process. The maximum internal cap is 32pF typically, and we suggest following the Realtek crystal design specification and QVL.

The external capacitor, C1 and C2, could be replaced by an internal capacitor, to reduce the BOM cost, minimize the PCB dimensions, and provide flexibility for clock fine-tuning.

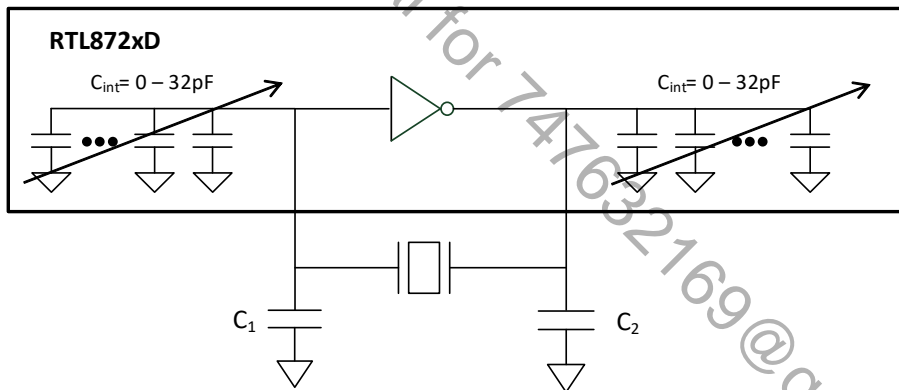

Figure 7-2 40MHz crystal specification suggestion

The specification of XTAL oscillation is listed in Table 7-7.

Table 7-7 Specification of crystal oscillator

Parameter	Min.	Typ.	Max.	Unit
Frequency	40			MHz
Mode of oscillation	Fundamental			
Frequency tolerance (25°C ± 3°C)	-10		+10	ppm
Equivalent Series Resistance (RR)		< 25	40	Ω
Temperature stability (-30°C ~ +85°C)	-10		+10	ppm
Load capacitance (CL)		12		pF
Drive level (DL)		150 ~ 200	300	uW
Shunt capacitance (C0)		< 0.88	2.0	pF

7.6 Power Consumption

The specification of power consumption is listed in Table 7-8.

Table 7-8 Specification of power consumption

Parameter	Condition	Typical	Maximum	Unit
Current	In sleep mode	38	105	uA
	In deepsleep mode	10	25	

7.7 Power State and Power Sequence

The timing specification of the power sequence is listed in Table 7-9.

Table 7-9 Timing specification of power sequence

Symbol	Parameter	Minimum	Typical	Maximum	Unit
T _{PRDY}	VDDx ready time	0.6	0.6	1	ms
T _{CLK}	Internal ring clock stable time after VDD1833 ready	1	-	-	ms
T _{core}	LP core power ready time	1.5	1.5	-	ms
T _{boot}	HS MCU boot time	200	200	-	ms
V _{RST}	Shutdown occurs after CHIP_EN lower than this voltage	0	0	0.5 * VDDx	V
T _{RST}	The required time that CHIP_EN lower than V _{RST}	1	1	-	ms

NOTE

VDDx is the supply power of VD1833.

7.7.1 Power on or Resuming from Deepsleep Sequence

The timing sequence of power on or resuming from deepsleep is given in Figure 7-3.

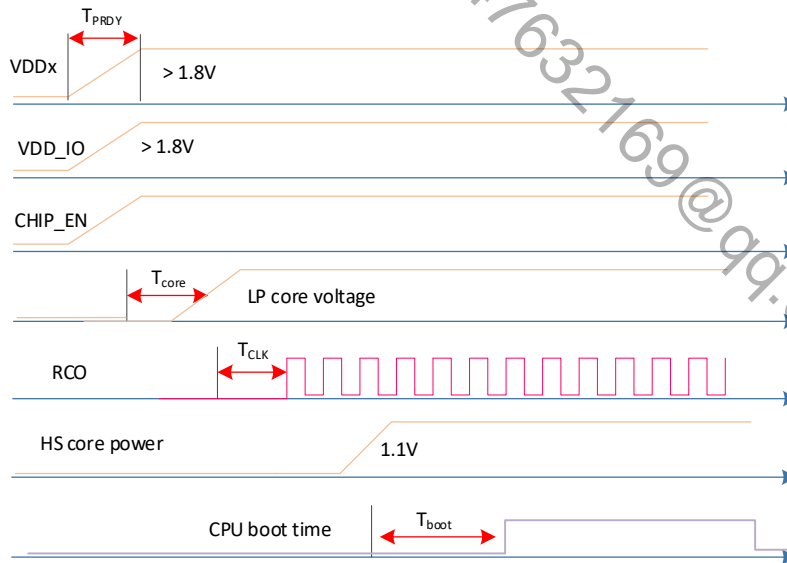

Figure 7-3 Timing sequence of power on or resuming from deepsleep

7.7.2 Shutdown Sequence

The timing sequence of shutdown is illustrated in Figure 7-4.

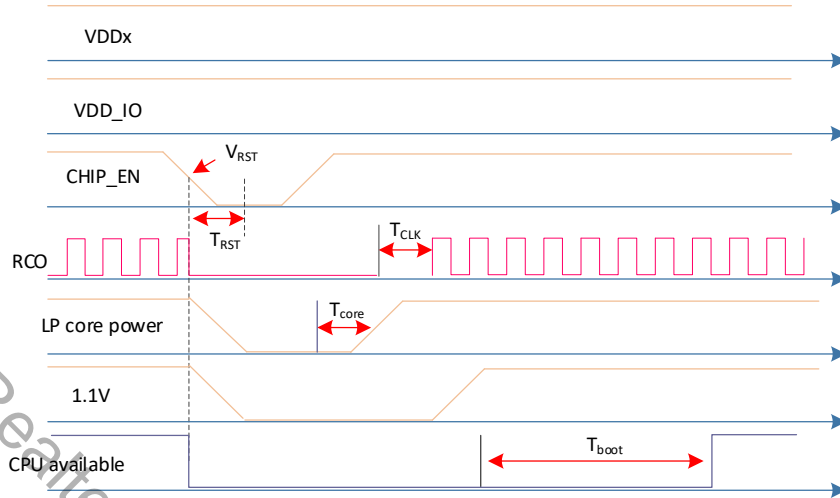

Figure 7-4 Timing sequence of shutdown

7.8 I/O Port Characteristics

7.8.1 GPIO Sink and Source Current

Test condition: I/O output mode.

- Sink current: I/O output low
- Source current: I/O output high

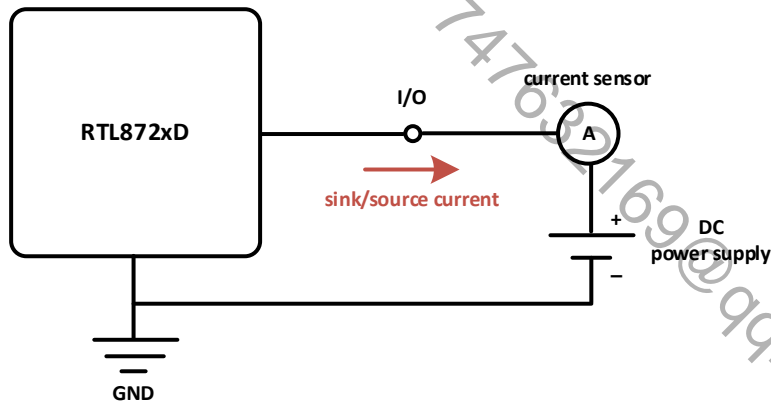

Figure 7-5 GPIO sink and source current test circuit

Table 7-10 GPIO sink and source current with 3.3V and 1.8V power supply

Pad type	Pin name		Driving strength (3.3V)		Driving strength (1.8V)	
	PA	PB	Source current (mA)	Sink current (mA)	Source current (mA)	Sink current (mA)
Normal ¹	PA[7]	PB[8]	5.9/10.96/15.1/18.8	5.1/9.6/13.3/16.7	2.0/3.8/5.4/6.9	1.9/3.5/5.0/6.4
	PA[8]	PB[9]				
	PA[9]	PB[10]				
	PA[10]	PB[11]				
	PA[11]	PB[12]				
	PA[22]	PB[13]				
	PA[23]	PB[14]				
	PA[24]	PB[15]				
	PA[27]	PB[16]				
	PA[28]	PB[17]				

SDIO ¹		PB[18] PB[19] PB[20] PB[21] PB[22] PB[23] PB[24] PB[25]	4.2/7.9/11.2/14.2/19.2/23.3	3.6/6.9/9.9/12.6/17.5/22.1	1.3/2.6/3.7/4.8/6.8/8.5	1.3/2.4/3.5/4.6/6.5/8.3
Key-Scan ¹	PA[12] PA[13] PA[14] PA[15] PA[16] PA[17] PA[18] PA[19] PA[20] PA[21] PA[25] PA[26]		11.0/18.9	9.7/16.8	3.9/7.1	3.6/6.7
Audio ¹	PA[0] PA[1] PA[2] PA[3] PA[4] PA[5] PA[6]	PB[28] PB[29] PB[30] PB[31]	6.1/13.9	6.1/15.3	2.1/5.4	2.2/6.2
Cap-Touch ²		PB[4] PB[5] PB[6] PB[7]	7.8/14.5	7.2/13.6	3.0/5.8	2.6/5.0
I2C ¹	PA[29] PA[30] PA[31]	PB[0] PB[26] PB[27] PB[1] PB[2] PB[3]	10.9/18.6	9.4/16.3	3.9/7.2	3.5/6.5

- For this type of GPIO pins with 3.3V power supply, external power supplies are set in 0.33V and 2.97V for testing sink current and source current respectively. For this type of GPIO pins with 1.8V power supply, external power supplies are set in 0.18V and 1.62V for testing sink current and source current respectively.
- For this type of GPIO pins with 3.3V power supply, external power supplies are set in 0.4V and 2.4V for testing sink current and source current respectively. For this type of GPIO pins with 1.8V power supply, external power supplies are set in 0.22V and 1.31V for testing sink current and source current respectively.

7.8.2 GPIO Pull Low Restriction

When one of the GPIOs listed below needs to be pulled low by a resistor on PCB, the pull low resistor value must > 1K Ohm.

Port Name	Schematic	Resistor Value
PA[7] ~ PA[31] PB[0] ~ PB[3] PB[8] ~ PB[17] PB[26] PB[27]		R > 1kΩ

8 Package Specifications

8.1 QFN48

The QFN48 package specification of RTL872xD is shown in Figure 8-1 and Table 8-1.

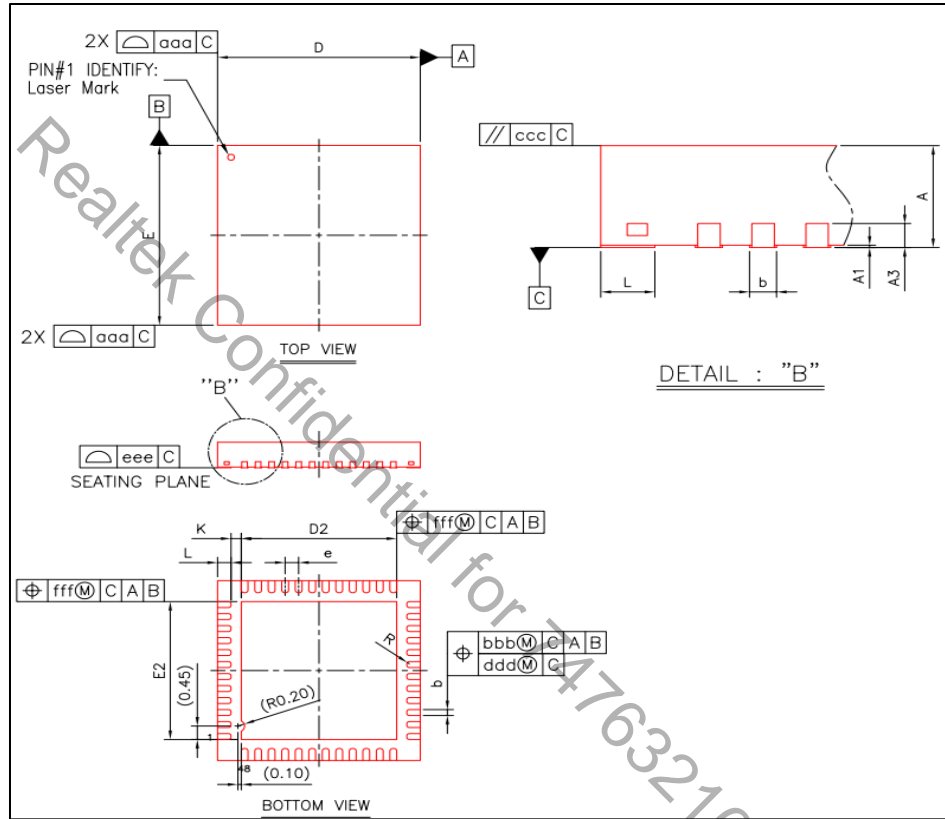

Figure 8-1 QFN48 package specification

Table 8-1 QFN48 package specification

Symbol	Dimension (mm)			Dimension (inch)		
	Minimum	Nominal	Maximum	Minimum	Nominal	Maximum
A	0.8	0.85	0.9	0.031	0.033	0.035
A ₁	0.00	0.02	0.05	0.000	0.001	0.002
A ₃	0.20REF			0.008REF		
b	0.15	0.20	0.25	0.006	0.008	0.010
D	6.00BSC			0.236BSC		
E	6.00BSC			0.236BSC		
D2/E2	4.50	4.60	4.70	0.177	0.181	0.185
e	0.40BSC			0.016BSC		
L	0.30	0.40	0.50	0.012	0.016	0.020
K	0.20	-	-	0.008	-	-
R	0.075	-	0.125	0.003	-	0.005
aaa	0.10			0.004		
bbb	0.07			0.003		
ccc	0.10			0.004		
ddd	0.05			0.002		

eee	0.08	0.003
fff	0.10	0.004

NOTE

- Controlling dimension: millimeter (mm).
- Reference document: JEDEC MO-220.

8.2 QFN68

The QFN68 package specification of RTL872xD is shown in Figure 8-2 and Table 8-2.

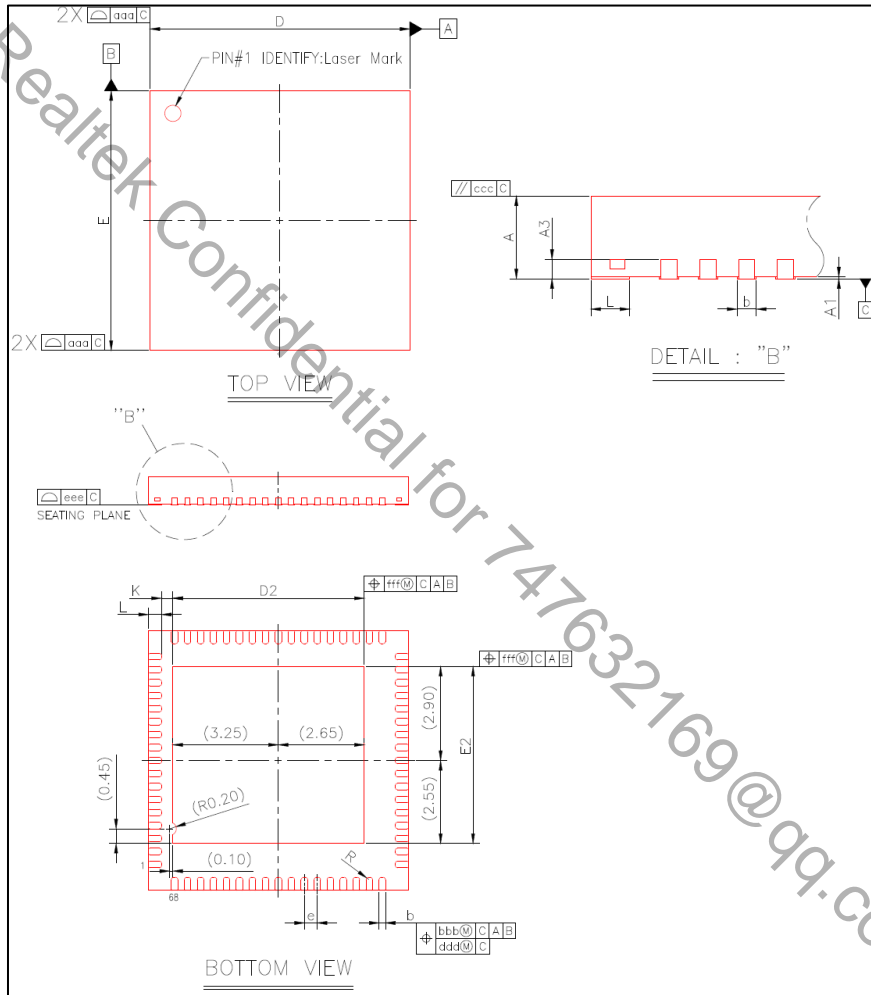

Figure 8-2 QFN68 package specification

Table 8-2 QFN68 package specification

Symbol	Dimension (mm)			Dimension (inch)		
	Minimum	Nominal	Maximum	Minimum	Nominal	Maximum
A	0.80	0.85	0.90	0.031	0.033	0.035
A ₁	0.00	0.02	0.05	0.000	0.001	0.002
A ₃	0.2 REF			0.008 REF		
b	0.15	0.20	0.25	0.006	0.008	0.010
D	7.90	8.00	8.10	0.311	0.315	0.319
E	7.90	8.00	8.10	0.311	0.315	0.319

D ₂	5.80	5.90	6.00	0.205	0.209	0.213
E ₂	5.35	5.45	5.55	0.217	0.220	0.224
e	0.40 BSC			0.016 BSC		
L	0.30	0.40	0.50	0.012	0.016	0.020
K	0.20	-	-	0.008	-	-
R	0.075	-	0.125	0.003	-	0.005
aaa	0.10			0.004		
bbb	0.07			0.003		
ccc	0.10			0.004		
ddd	0.05			0.002		
eee	0.08			0.003		
fff	0.10			0.004		

NOTE

- Controlling dimension; millimeter (mm).
- Reference document; JEDEC MO-220.

8.3 QFN88

The QFN88 package specification of RTL872xD is shown in Figure 8-3 and Table 8-3.

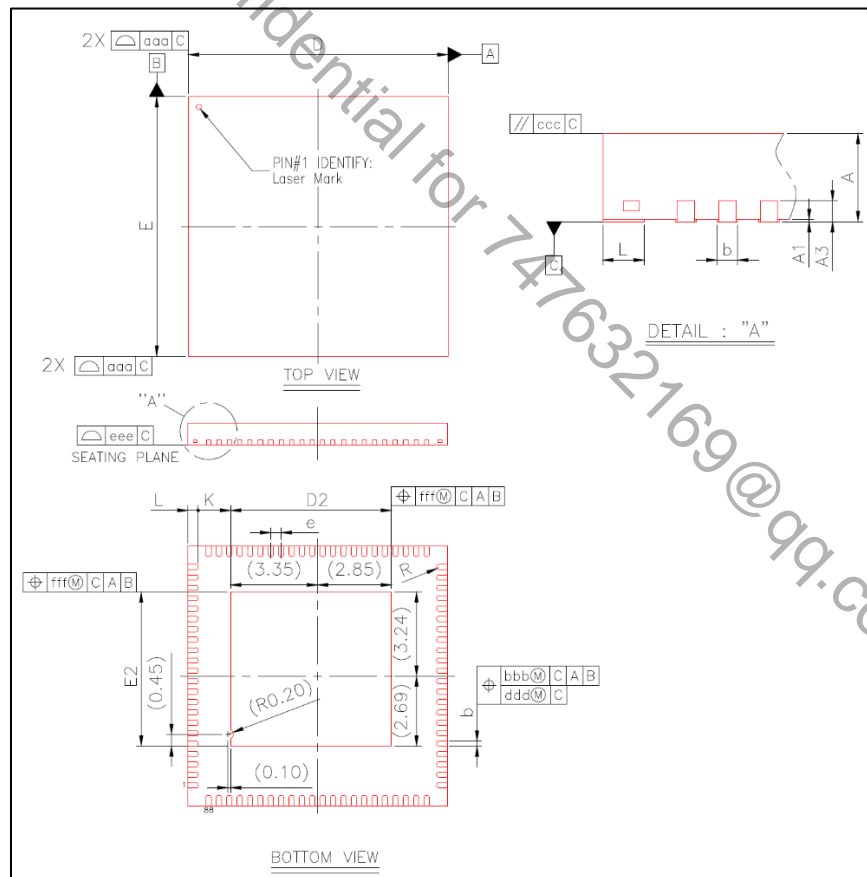

Figure 8-3 QFN88 package specification

Table 8-3 QFN88 package specification

Symbol	Dimension (mm)			Dimension (inch)		
	Minimum	Nominal	Maximum	Minimum	Nominal	Maximum

A	0.80	0.85	0.90	0.031	0.033	0.035
A ₁	0.00	0.02	0.05	0.000	0.001	0.002
A ₃	0.20 REF			0.008 REF		
b	0.15	0.20	0.25	0.006	0.008	0.010
D	9.90	10.00	10.10	0.390	0.394	0.398
E	9.90	10.00	10.10	0.390	0.394	0.398
D ₂	6.10	6.20	6.30	0.240	0.244	0.248
E ₂	5.83	5.93	6.03	0.230	0.233	0.237
e	0.40 BSC			0.016 BSC		
L	0.30	0.40	0.50	0.012	0.016	0.020
K	0.20	-	-	0.008	-	-
R	0.075	-	0.125	0.003	-	0.005
aaa	0.10			0.004		
bbb	0.07			0.003		
ccc	0.10			0.004		
ddd	0.05			0.002		
eee	0.08			0.003		
fff	0.10			0.004		

i NOTE

- Controlling dimension: millimeter (mm).
- Reference document: JEDEC MO-220.

Realtek Confidential for 747632169@qq.com

List of Tables

Table 1-1 System and memory features	9
Table 1-2 Wireless features	10
Table 1-3 Security features	10
Table 1-4 Communication interface features	10
Table 1-5 Audio features	12
Table 1-6 Timer features	13
Table 1-7 Human- machine interaction features	13
Table 1-8 Analog features	14
Table 1-9 Peripherals under different packages	15
Table 1-10 Memory under different packages	16
Table 2-1 Package types	17
Table 2-2 Low power pins	23
Table 2-3 Pin default configuration	23
Table 2-4 Trap pins	23
Table 3-1 Pin type description	25
Table 3-2 Power on trap pins	25
Table 3-3 RF pins	25
Table 3-4 Chip enable pin	25
Table 3-5 Power pins	26
Table 3-6 XTAL pins	26
Table 3-7 ADC and Cap-Touch pins	26
Table 3-8 USB pins	27
Table 3-9 Audio codec pins	27
Table 4-1 Address space main blocks	28
Table 4-2 KM4 register boundary addresses	28
Table 4-3 KM0 register boundary addresses	30
Table 5-1 NVIC table	33
Table 7-1 Temperature limit ratings	39
Table 7-2 ESD characteristics	39
Table 7-3 Power supply DC characteristics	39
Table 7-4 Digital I/O pin DC characteristics (3.3V)	40
Table 7-5 Digital I/O pin DC characteristics (1.8V)	40
Table 7-6 SAR ADC characteristics	40
Table 7-7 Specification of crystal oscillator	41
Table 7-8 Specification of power consumption	42
Table 7-9 Timing specification of power sequence	42
Table 7-10 GPIO sink and source current with 3.3V and 1.8V power supply	43
Table 8-1 QFN48 package specification	45
Table 8-2 QFN68 package specification	46
Table 8-3 QFN88 package specification	47

List of Figures

Figure 1-1 System architecture 8

Figure 2-1 QFN48 pin assignments for RTL8720DN/RTL8720DM 19

Figure 2-2 QFN48 pin assignments for RTL8720DF 20

Figure 2-3 QFN68 pin assignment for RTL8721DM 21

Figure 2-4 QFN88 pin assignments for RTL8722DM 22

Figure 5-1 NVIC diagram 32

Figure 6-1 RF block diagram 35

Figure 7-1 Power-on waveform 40

Figure 7-2 40MHz crystal specification suggestion 41

Figure 7-3 Timing sequence of power on or resuming from deepsleep 42

Figure 7-4 Timing sequence of shutdown 43

Figure 7-5 GPIO sink and source current test circuit 43

Figure 8-1 QFN48 package specification 45

Figure 8-2 QFN68 package specification 46

Figure 8-3 QFN88 package specification 47

All rights reserved. Confidential for 747632169@qq.com

Revision History

Date	Version	Description
2021-01-20	v2.9	Update the ordering information
2020-11-4	v2.8	<ul style="list-style-type: none"> ● Add the section: GPIO Sink and Source Current ● Add the section: ESD Characteristics ● Add the information of RTL8720DF (QFN48)
2020-08-17	v2.7	<ul style="list-style-type: none"> ● Add the section: ADC Characteristics ● Update the ordering information
2020-06-24	v2.6	<ul style="list-style-type: none"> ● Update the ordering information ● Update the chapter: Memory Organization ● Update the RF receiver specification ● Update the figure: System architecture ● Add the section: XTAL Oscillator ● Add the section: Power Consumption ● Update the feature of UART ● Add some restrictions for Power Supply
2020-02-18	v2.5	Update the feature of USB
2020-02-13	v2.4	Add some description of PA[15] & PA[16] for QFN48
2020-01-13	v2.3	Update the features
2019-12-25	v2.2	<ul style="list-style-type: none"> ● Update the temperature limit ● Update the part number and ordering information
2019-12-09	v2.1	<ul style="list-style-type: none"> ● Update the chapter: Memory Organization ● Update the section: General Description ● Update the specifications of Wi-Fi 2.4GHz/5GHz RF transmitter output power
2019-09-20	v2.0	<ul style="list-style-type: none"> ● Add the section: BT Radio Characteristics ● Update the value of Wi-Fi RF transmitter
2019-07-19	v1.9	Update the section: Package Types
2019-06-03	v1.8	<ul style="list-style-type: none"> ● Update the description of Flash features ● Update the BLE Tx power to 8dbm ● Update the table: Power supply DC characteristics
2019-04-10	v1.7	<ul style="list-style-type: none"> ● Add the chapter: Radio Characteristics ● Update the table: Timing specification of power sequence ● Update the table: Power supply DC characteristics ● Add the note of interrupt priority ● Add the section: GPIO Pull Low Restriction Update the pin assignments for <ul style="list-style-type: none"> ● QFN88
2019-02-21	v1.6	<ul style="list-style-type: none"> ● Add RFGND pin to RF pins table ● Re-organize the section: DC Characteristics
2019-01-25	v1.5	<ul style="list-style-type: none"> ● Modify the pin name (pin49) of QFN88 package ● Update the memory address
2018-12-26	v1.4	Update the package specification of QFN68
2018-12-20	v1.3	<ul style="list-style-type: none"> ● Update the peripherals under different packages ● Revise the incorrect pin number
2018-12-17	v1.2	Update the description of power pins
2018-12-13	v1.1	<ul style="list-style-type: none"> ● Re-organize the structure of document ● Update package types of RTL872xD and QFN68/QFN88 pin assignments ● Update the operating temperature limit
2018-10-18	v1.0	Add the description about AUDIO_GND
2018-10-09	v0.9	<ul style="list-style-type: none"> ● Add description about SDIO device time consuming ● Unify and normalize the technical items and expression
2018-07-04	v0.8	Add pin default configuration when boot

2018-07-04	v0.7	Change audio & Secure
2018-07-04	v0.6	Change system architecture
2018-07-03	v0.5	Update system architecture
2018-06-29	v0.4	Update power architecture
2018-06-28	v0.3	Add Peripherals
2018-06-27	v0.2	Add all features
2018-06-24	v0.1	Draft version

Realtek Confidential for 747632169@qq.com