

1

2

3

4

5

6

7

8

A

A

B

B

C

C

D

D

E

E

REV	Description	DATE	BY
1	First version	20190812	Milo

# Seed Studio

TITLE: wio terminal

CC-BY-SA

Design:

Check:

Date: 尚未保存!

Vision:

Sheet: 1/1

1

2

3

4

5

6

7

8

# ATSAMD51P19A

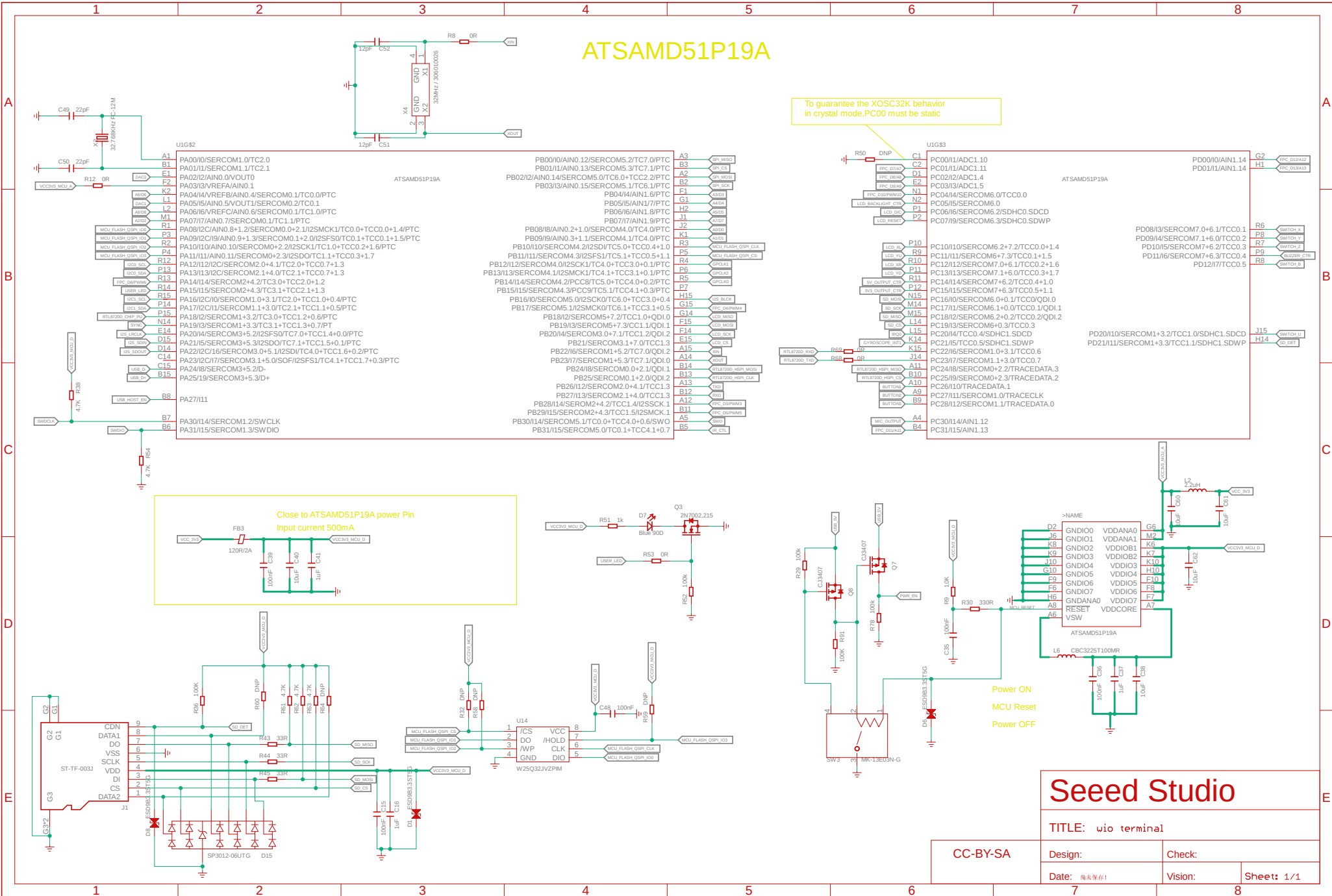

## Seed Studio

TITLE: wio terminal

CC-BY-SA

Design:

Check:

Date: 萬米保存!

Vision:

Sheet: 1/1



# Buzzer & MIC

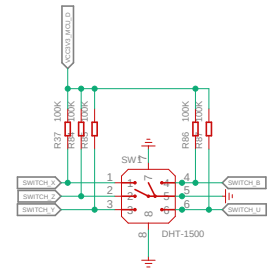
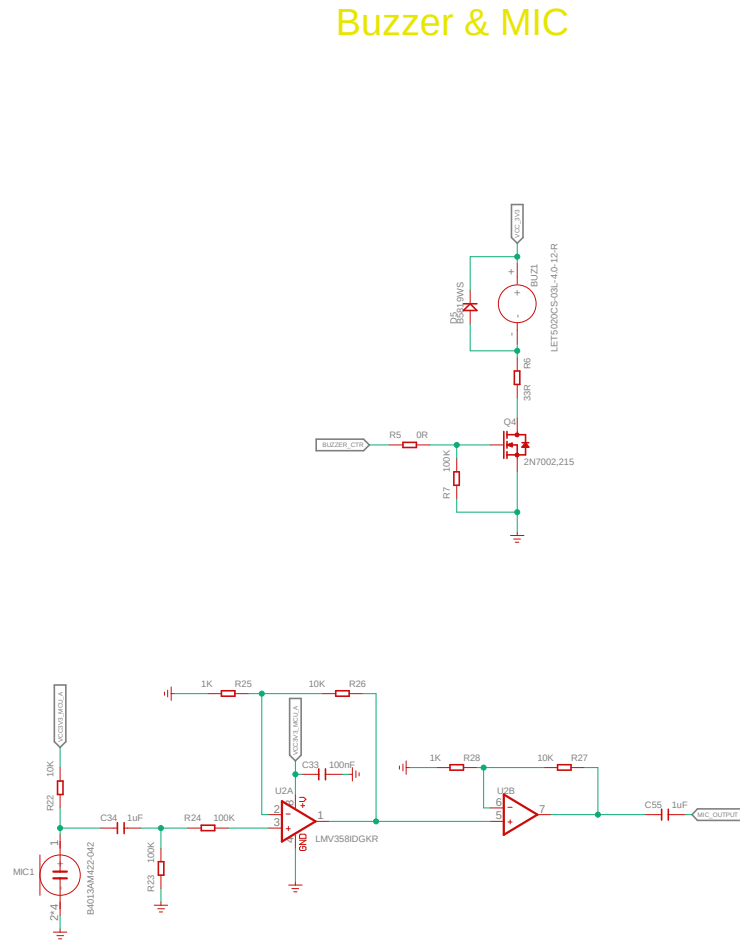

<b>Seed Studio</b>			
TITLE: wio terminal			
Design:		Check:	
Date: 尚未保存!		Vision:	Sheet: 1/1

CC-BY-SA

# Header Interface and Button

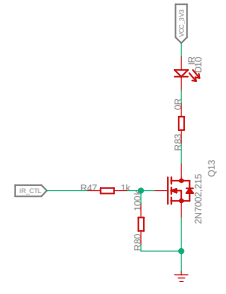
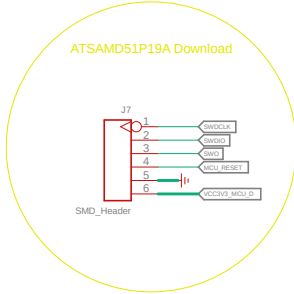
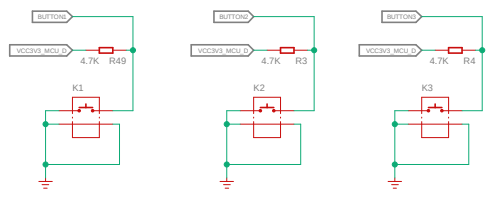
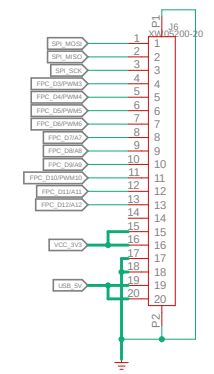
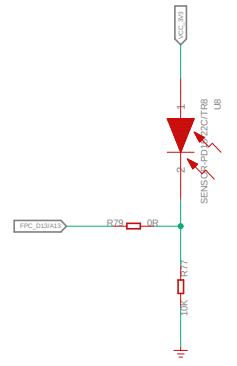
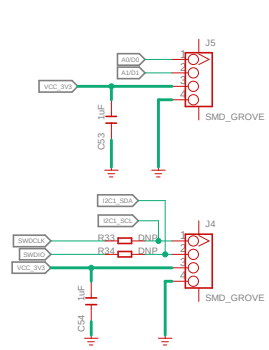
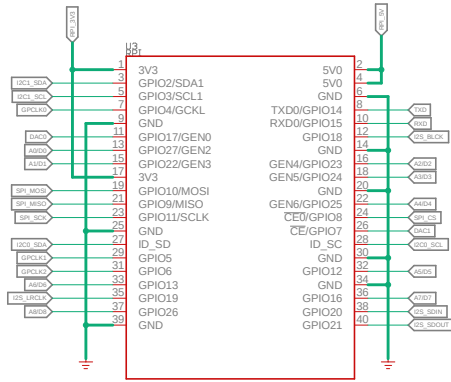

**Seed Studio**

TITLE: wio terminal

CC-BY-SA	Design:	Check:
	Date: 高亮保存!	Vision:



# WIFI+BLE

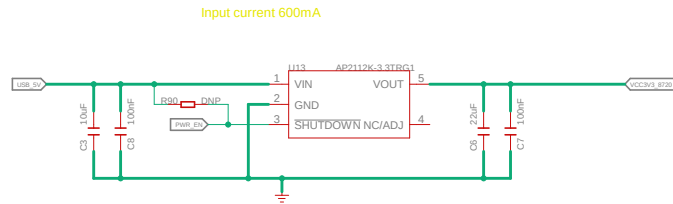
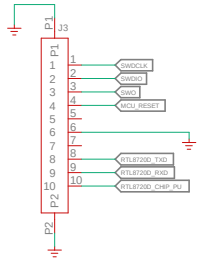

PB14/SPI\_DATA0  
 PB13/SPI\_CLK  
 PB16/SPI\_CS  
 PB17/SPI\_DATA1  
 PB20/TXD/PWM12/I2S\_CLK/SPI\_DATA0/I2C\_SCL  
 PB21/RXD/PWM13/I2S\_WS/SPI\_CLK/I2C\_SDA  
 CHIP\_EN  
 UART\_LOG\_TXD  
 UART\_LOG\_RXD

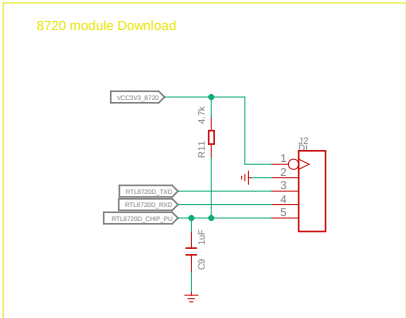
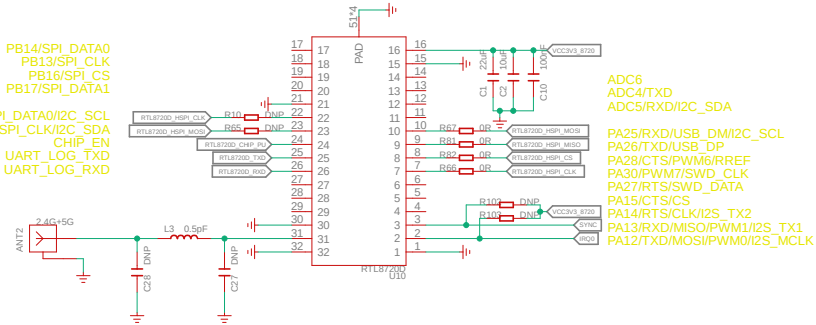

<h2>Seeed Studio</h2>			
		TITLE: wio terminal	
CC-BY-SA	Design:	Check:	
	Date: 尚未保存!	Vision:	Sheet: 1/1